

Refrigeration Product & Application Catalog

FlatPlate[®] By GEA PHE Systems NA, Inc.

- Liquid DX Evaporators
- Condenser/Heat Pumps
- Industrial Condensers
- Subcoolers
- Fluid to Fluid
- Special Applications
- Shell and Tube Replacement



Brazed Plate Heat Exchangers



Process Equipment Division
GEA PHE Systems NA, Inc.

Refrigeration Heat Exchangers

21ST Century Technology

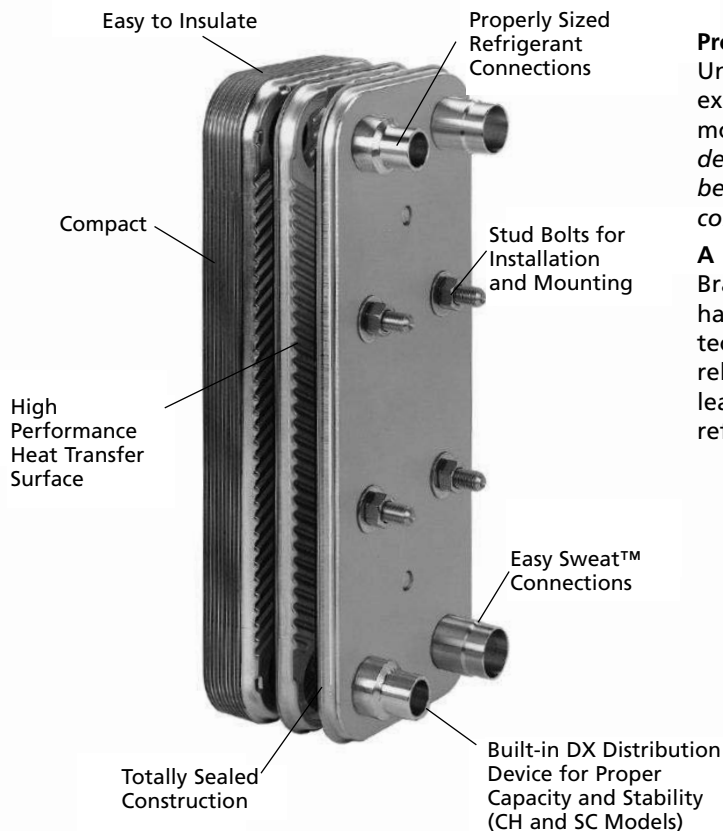

Proven Performance

Unique to FlatPlate[®] is exacting performance and expertise from the factory. In this catalog there are select models specifically designed for refrigeration. FlatPlate[®] designs have been tested for proven performance and can be computer selected for a wide range of operating conditions, fluids, and applications.

A History of Reliability

Braze plate heat exchangers have a solid background and have evolved from 60 years of plate heat exchanger technology. With FlatPlate[®], all models have field proven reliability and important features built-in. FlatPlate[®] is the leading innovator in the U.S. of this technology for refrigeration and hydronics.

Working Temperatures: -320°F to 350°F
Working Pressures: to 450 psig
Refrigerants: R22, R134a, R407c
R404a, R410a
& others

Approvals: U.L. Listed, U.S. and Canada
Canadian CRN
European CE (optional)
ASME Stamped (optional)



Simply Effective

FlatPlate[®]'s Brazed Plate Heat Exchangers consist of 10 to 200 specially formed stainless steel plates, which are then copper brazed together in a vacuum furnace for leak tight, rugged construction. When stacked, the plates form two separate flow passages between the plates, thus allowing a liquid or refrigerant to flow between every other plate. This provides heat transfer and complete separation of the fluids and gases. With FlatPlate[®]'s high performance heat transfer surface, a very compact, cost effective design is the result.

Four Reasons to Use GEA FlatPlate[®]

GEA PHE Systems heat exchangers have significant advantages.

1. **Smaller Size** - FlatPlate[®] heat exchangers are 20% to 60% smaller than traditional shell & tube and coaxial type devices. This means they use less space, weigh less and require less refrigerant charge.
2. **Higher Performance** - Plate heat exchangers have higher heat transfer coefficients. This means improved performance and greater versatility for standard applications, high viscosity fluids and special design conditions. In addition, lower fouling rates contribute to long life efficiency.
3. **Lower Cost** - FlatPlate[®] heat exchangers cost 10% to 30% less than other types of comparable heat exchangers. Installation costs are also lower.
4. **Customer Service** - We provide customer service, computer selections, and excellent technical support.

Refrigeration Heat Exchangers

We Speak Refrigeration™.....

Applications for FlatPlate® heat exchangers in air conditioning and refrigeration systems span the full range of compressorized systems, in both OEM and Contractor installed equipment.

FlatPlate® heat exchangers models are used as Evaporators, Fluid Chillers, Condensers, Subcoolers, Economizers, Compressor Oil Coolers, Gas Driers, and much more. Standard models can be configured for all most any application, and custom models are also available.

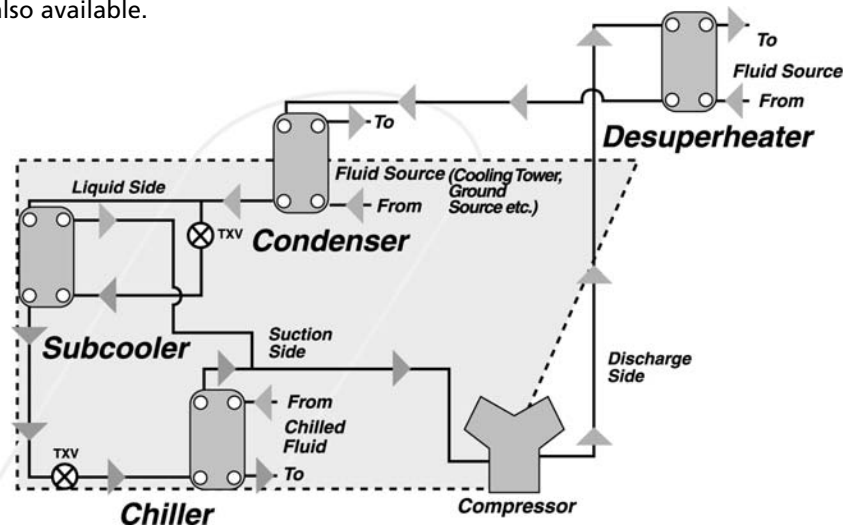

Here are the many FlatPlate® applications:

Water Chillers for:

Comfort Cooling, Air Conditioning Systems
 Comfort Heating/Cooling, Heat Pumps
 Computer Room Systems
 Ships & Yachts

Process Chillers for:

Machine Cooling
 MRI/X-Ray Machines
 Lasers
 Plastics Injection Mold Cooling
 Food Process
 Semi-conductor Systems
 De-ionized Water Chilling
 Laboratory Chillers

Glycol Chillers for:

Low Temperature Processes
 Food Processes
 Printing Presses
 Ice Rinks
 Special Processes

Economizers/Subcoolers

DX Refrigerant to Refrigerant

Supermarket Systems

Subcoolers
 Fluid Coolers
 Condensers

Ice Making Machines

Condensers
 Pre-coolers

Environmental Chambers

Cascade Condensers
 Desuperheaters

Compressed Air & Gas Driers

Refrigerant to Gas
 Gas to Gas re-heater

Hydraulic Oil Cooling

Refrigerant to Oil
 Oil to Water

Hydrocarbon Processing

Condensers
 Evaporators/Chillers

Beverage, Beer, & Wine Cooling

Glycol to Fluid

Swimming Pool Heating/Cooling

Heating
 Cooling

Direct Expansion Evaporators

CH Series

1/2 to 80 tons



FlatPlate®'s brazed plate CH series DX evaporators represent a breakthrough in heat transfer technology. They offer a cost efficient alternative to conventional "chiller barrels" and other liquid chiller designs. The CH series is designed specifically for DX water chilling and fluid cooling applications that utilize R-22, R-134a, R-404a, R-407c and other halocarbon refrigerants. The advantages of FlatPlate®'s CH series DX evaporators include their compact size and lighter weight, which reduce shipping and installation costs. All CH series models are made from copper brazed 316L stainless steel plates and are pressure rated to 450 psig on both the refrigerant side and the liquid side. Select models have a built-in DX distributor for enhanced operation. All CH series models are U.L. Listed, with ASME code optional.

5" x 12" Models

Model	Tons	Application ¹	Width	Length	Depth	Refrig Out	Refrig In	Fluid	Net Wt. (lbs.)
CH1/2A	.5	Liquid Chiller	4.9	12.2	1.1	5/8 ID	5/8 ID	7/8 ID	6
CH3/4A	.75	Liquid Chiller	4.9	12.2	1.3	5/8 ID	5/8 ID	7/8 ID	7
CH1A	1	Liquid Chiller	4.9	12.2	1.5	5/8 ID	5/8 ID	7/8 ID	7
CH1-1/2A	1.5	Liquid Chiller	4.9	12.2	1.9	5/8 ID	5/8 ID	7/8 ID	9
CH2A	2	Liquid Chiller	4.9	12.2	2.2	5/8 ID	5/8 ID	7/8 ID	10
CH2-1/2A	2.5	Liquid Chiller	4.9	12.2	2.6	5/8 ID	5/8 ID	7/8 ID	11
CH3A	3	Liquid Chiller	4.9	12.2	3.2	5/8 ID	5/8 ID	7/8 ID	13
CH3-1/2A	3.5	Liquid Chiller	4.9	12.2	3.7	7/8 ID	5/8 ID	7/8 ID	15
CH4A	4	Liquid Chiller	4.9	12.2	4.5	7/8 ID	5/8 ID	1-1/8 ID	18
CH5A	5	Liquid Chiller	4.9	12.2	5.4	7/8 ID	5/8 ID	1-1/8 ID	21

5" x 20" Models

Model	Tons	Application ¹	Width	Length	Depth	Refrig Out	Refrig In	Fluid	Net Wt. (lbs.)
CH1-1/2	1.5	Liquid Chiller	5.0	20.3	1.1	5/8 ID	5/8 ID	7/8 ID	10
CH2	2	Liquid Chiller	5.0	20.3	1.3	5/8 ID	5/8 ID	7/8 ID	11
CH2-1/2	2.5	Liquid Chiller	5.0	20.3	1.5	5/8 ID	5/8 ID	7/8 ID	13
CH3	3	Liquid Chiller	5.0	20.3	1.7	5/8 ID	5/8 ID	7/8 ID	14
CH3-1/2	3.5	Liquid Chiller	5.0	20.3	2.1	5/8 ID	5/8 ID	7/8 ID	16
CH4	4	Liquid Chiller	5.0	20.3	2.3	7/8 ID	5/8 ID	1-1/8 ID	17
CH5	5	Liquid Chiller	5.0	20.3	2.6	7/8 ID	5/8 ID	1-1/8 ID	19
CH6	6	Liquid Chiller	5.0	20.3	3.2	1-1/8 ID	7/8 ID	1-1/8 ID	23
CH7-1/2	7.5	Liquid Chiller	5.0	20.3	4.1	1-1/8 ID	7/8 ID	1-1/8 ID	28
CH10B	10	Liquid Chiller	5.0	20.3	5.1	1-3/8 ID	7/8 ID	1-3/8 ID	34
CH12B	12.5	Liquid Chiller	5.0	20.3	6.0	1-3/8 ID	7/8 ID	1-3/8 ID	40
CH15B	15	Liquid Chiller	5.0	20.3	7.0	1-3/8 ID	7/8 ID	1-3/8 ID	45

10" x 20" Models

Model	Tons	Application ¹	Width	Length	Depth	Refrig Out	Refrig In	Fluid	Net Wt. (lbs.)
CH10	10	Liquid Chiller	9.8	20.3	2.6	1-3/8 ID	7/8 ID	1-5/8 ID	38
CH12	12.5	Liquid Chiller	9.8	20.3	3.2	1-3/8 ID	7/8 ID	1-5/8 ID	44
CH15	15	Liquid Chiller	9.8	20.3	4.1	1-3/8 ID	7/8 ID	1-5/8 ID	55
CH20	20	Liquid Chiller	9.8	20.3	5.1	1-5/8 ID	7/8 ID	1-5/8 ID	66
CH25	25	Liquid Chiller	9.8	20.3	6.0	1-5/8 ID	1-1/8 ID	2-1/8 ID	77
CH30	30	Liquid Chiller	9.8	20.3	6.9	2-1/8 ID	1-1/8 ID	2-1/8 ID	88
CH35	35	Liquid Chiller	9.8	20.3	8.8	2-1/8 ID	1-1/8 ID	2-5/8 ID	110
CH40	40	Liquid Chiller	9.8	20.3	9.8	2-1/8 ID	1-1/8 ID	2-5/8 ID	121
CH50	50	Liquid Chiller	9.8	20.3	12.6	2-5/8 ID	1-1/8 ID	2-5/8 ID	154
CH60	60	Liquid Chiller	9.8	20.3	14.5	2-5/8 ID	1-1/8 ID	2-5/8 ID	176
CH70	70	Liquid Chiller	9.8	20.3	16.3	2-5/8 ID	1-1/8 ID	2-5/8 ID	198
CH80	80	Liquid Chiller	9.8	20.3	19.2	2-5/8 ID	1-1/8 ID	2-5/8 ID	231

- Notes:**
1. Nominal tons - 12,000 BTUH per ton, 54°F EWT, 44°LWT, 35°F Evap Temp, 6°F Superheat, 2.4 gpm per ton, R-22.
 2. For Glycol, special fluids or design conditions other than listed above, please contact the factory for special computer selection.

- Options:**
1. For fittings and configurations other than standard, consult the factory for pricing.
 2. For ASME code version, the model number should include "-UM". Example CH40-UM
 3. For R-410a applications, the model number should include "-XP". Example CH40-XP

Two Refrigerant Circuit

2C Series

3 to 80 tons



FlatPlate® offers the most advanced and cost effective heat exchanger for two compressor systems, liquid chillers and for shell & tube replacement. The 2C Series is designed for R22, R407c, R134a, R404a and other halocarbon refrigerants for DX evaporator, condenser and heat pump operation. Two Refrigerant Circuits are “inter-laced” with the fluid side, such that 100% of the fluid is cooled when one compressor is operating. High Performance and very compact, all 2C models are made from copper brazed, 316L stainless steel plates and rated for 450 psig on refrigerant side and 350 psig on liquid side. Select models have a built-in DX distributor for enhanced operation. All 2C models are U.L. Listed, with optional ASME code and optional European CE code.

Liquid Chillers

Model	Tons	Application¹	Width	Length	Depth	Refrig In	Refrig Out	Fluid	Net Wt. (lbs.)
CH3-2C	3	Liquid Chiller	9.8	20.3	1.3	5/8 ID	7/8 ID	1" MPT	22
CH5-2C	5	Liquid Chiller	9.8	20.3	1.7	5/8 ID	7/8 ID	1" MPT	27
CH6-2C	6	Liquid Chiller	9.8	20.3	2.1	5/8 ID	7/8 ID	1" MPT	31
CH8-2C	8	Liquid Chiller	9.8	20.3	2.4	5/8 ID	7/8 ID	1" MPT	35
CH10-2C	10	Liquid Chiller	9.8	20.3	2.8	7/8 ID	1-1/8 ID	1-1/2" MPT	40
CH12-2C	12.5	Liquid Chiller	9.8	20.3	3.2	7/8 ID	1-1/8 ID	1-1/2" MPT	44
CH15-2C	15	Liquid Chiller	9.8	20.3	3.9	7/8 ID	1-1/8 ID	1-1/2" MPT	53
CH20-2C	20	Liquid Chiller	9.8	20.3	5.1	7/8 ID	1-3/8 ID	1-1/2" MPT	66
CH25-2C	25	Liquid Chiller	9.8	20.3	6.2	7/8 ID	1-3/8 ID	2" MPT	79
CH30-2C	30	Liquid Chiller	9.8	20.3	7.3	7/8 ID	1-3/8 ID	2" MPT	93
CH35-2C	35	Liquid Chiller	9.8	20.3	8.8	7/8 ID	1-3/8 ID	2" MPT	110
CH40-2C	40	Liquid Chiller	9.8	20.3	9.9	7/8 ID	1-5/8 ID	2-1/2" MPT	124
CH50-2C	50	Liquid Chiller	9.8	20.3	12.6	1-1/8 ID	1-5/8 ID	2-1/2" MPT	157
CH60-2C	60	Liquid Chiller	9.8	20.3	14.5	1-1/8 ID	2-1/8 ID	2-1/2" MPT	179
CH70-2C	70	Liquid Chiller	9.8	20.3	16.3	1-1/8 ID	2-1/8 ID	2-1/2" MPT	201
CH80-2C	80	Liquid Chiller	9.8	20.3	19.2	1-1/8 ID	2-1/8 ID	2-1/2" MPT	234

Condensers

Model	Tons	Application¹	Width	Length	Depth	Refrig In	Refrig Out	Fluid	Net Wt. (lbs.)
C3-2C	3	Condenser	9.8	20.3	1.3	7/8 ID	5/8 ID	1" MPT	18
C5-2C	5	Condenser	9.8	20.3	1.7	7/8 ID	5/8 ID	1" MPT	22
C6-2C	6	Condenser	9.8	20.3	2.1	7/8 ID	5/8 ID	1" MPT	27
C8-2C	8	Condenser	9.8	20.3	2.4	7/8 ID	5/8 ID	1" MPT	31
C10-2C	10	Condenser	9.8	20.3	2.8	1-1/8 ID	7/8 ID	1-1/2" MPT	36
C12-2C	12.5	Condenser	9.8	20.3	3.2	1-1/8 ID	7/8 ID	1-1/2" MPT	45
C15-2C	15	Condenser	9.8	20.3	3.6	1-1/8 ID	7/8 ID	1-1/2" MPT	49
C20-2C	20	Condenser	9.8	20.3	4.3	1-3/8 ID	7/8 ID	1-1/2" MPT	58
C25-2C	25	Condenser	9.8	20.3	5.1	1-3/8 ID	7/8 ID	2" MPT	67
C30-2C	30	Condenser	9.8	20.3	6.0	1-3/8 ID	7/8 ID	2" MPT	80
C40-2C	40	Condenser	9.8	20.3	8.1	1-5/8 ID	1-1/8 ID	2-1/2" MPT	102
C50-2C	50	Condenser	9.8	20.3	9.9	1-5/8 ID	1-1/8 ID	2-1/2" MPT	124
C60-2C	60	Condenser	9.8	20.3	12.6	2-1/8 ID	1-1/8 ID	2-1/2" MPT	155
C70-2C	70	Condenser	9.8	20.3	14.5	2-1/8 ID	1-1/8 ID	2-1/2" MPT	177
C80-2C	80	Condenser	9.8	20.3	16.3	2-1/8 ID	1-1/8 ID	2-1/2" MPT	188

Notes:

1. All models include (2) 1/2" FPT Waterside Temperature Probe Fittings.
2. CH models have built-in DX distributors, HP Models have built-in reverse cycle DX Distributor.
3. CH & HP models nominal rating at 54F EWT, 44F LWT, 35F Et, R22
4. C models nominal rating at 85F EWT, 95F LWT, 105F Ct, R22

Options:

1. For fittings and configurations other than standard, consult the factory for pricing.
2. For ASME code version, the model number should include "-UM".
Example: CH40-2C-UM
3. For R-410a applications, the model number should include "-XP". Example CH40-2C-XP

CHN Direct Expansion Evaporators

All Stainless, Nickel Brazed

1/2 to 80 tons



For de-ionized water, solvents, and fluids not compatible with copper, FlatPlate®'s ALL STAINLESS, Nickel brazed models are industry standards. The CHN Series is designed for DX (direct expansion) fluid cooling applications that utilize R22, R134a, R4040a, R407c, and other halocarbon refrigerants. Extremely compact and cost effective, the CHN Series is made with 316L stainless steel plates, nickel brazed. All models have sweat solder connections on the refrigerant side and MPT on the fluid side, and select models have a built-in DX distributor for enhanced operation. All CHN models are U.L. Listed, optional ASME Code, and optional European Code.

5" x 12" Models

Model	Tons	Width	Length	Depth	Refrig In	Refrig Out	Fluid	Net Wt. (lbs.)
CHN1/2A (1" MPT)	1/2	4.9	12.2	1.1	5/8	5/8	1 MPT	16
CHN3/4A (1" MPT)	3/4	4.9	12.2	1.3	5/8	5/8	1 MPT	17
CHN1A (1" MPT)	1	4.9	12.2	1.5	5/8	5/8	1 MPT	18
CHN1-1/2A (1" MPT)	1-1/2	4.9	12.2	1.9	5/8	5/8	1 MPT	19
CHN2A (1" MPT)	2	4.9	12.2	2.2	5/8	5/8	1 MPT	21
CHN2-1/2A (1" MPT)	2-1/2	4.9	12.2	2.6	5/8	5/8	1 MPT	22
CHN3A (1" MPT)	3	4.9	12.2	3.2	5/8	5/8	1 MPT	24
CHN3-1/2A (1" MPT)	3-1/2	4.9	12.2	3.7	5/8	7/8	1 MPT	26
CHN4A (1" MPT)	4	4.9	12.2	4.5	5/8	7/8	1 MPT	28
CHN5A (1" MPT)	5	4.9	12.2	5.4	5/8	7/8	1 MPT	33

5" x 20" Models

Model	Tons	Width	Length	Depth	Refrig In	Refrig Out	Fluid	Net Wt. (lbs.)
CHN1-1/2 (1" MPT)	1-1/2	5	20.3	1.1	5/8	5/8	1 MPT	28
CHN2 (1" MPT)	2	5	20.3	1.3	5/8	5/8	1 MPT	29
CHN2-1/2 (1" MPT)	2-1/2	5	20.3	1.5	5/8	5/8	1 MPT	30
CHN3 (1" MPT)	3	5	20.3	1.7	5/8	5/8	1 MPT	31
CHN3-1/2 (1" MPT)	3-1/2	5	20.3	2.1	5/8	5/8	1 MPT	34
CHN4 (1" MPT)	4	5	20.3	2.2	5/8	7/8	1 MPT	35
CHN5 (1" MPT)	5	5	20.3	2.6	5/8	7/8	1-1/4 MPT	37
CHN6 (1" MPT)	6	5	20.3	3.2	7/8	1-1/8	1-1/4 MPT	41
CHN7-1/2 (1" MPT)	7-1/2	5	20.3	4.1	7/8	1-1/8	1-1/4 MPT	47
CHN10B (1" MPT)	10	5	20.3	5.1	7/8	1-3/8	1-1/4 MPT	52
CHN12B (1" MPT)	12	5	20.3	6.0	7/8	1-3/8	1-1/4 MPT	58
CHN15B (1" MPT)	15	5	20.3	6.9	7/8	1-3/8	1-1/4 MPT	64

10" x 20" Models

Model	Tons	Width	Length	Depth	Refrig In	Refrig Out	Fluid	Net Wt. (lbs.)
CHN10 (1-1/2" MPT)	10	9.8	20.3	2.6	7/8	1-3/8	1-1/2 MPT	60
CHN12 (1-1/2" MPT)	12	9.8	20.3	3.2	7/8	1-3/8	1-1/2 MPT	67
CHN15 (1-1/2" MPT)	15	9.8	20.3	4.1	7/8	1-3/8	1-1/2 MPT	80
CHN20 (1-1/2" MPT)	20	9.8	20.3	5.1	7/8	1-5/8	1-1/2 MPT	92
CHN25 (2" MPT)	25	9.8	20.3	6.0	1-1/8	1-5/8	2 MPT	105
CHN30 (2" MPT)	30	9.8	20.3	6.9	1-1/8	2-1/8	2 MPT	117
CHN35 (2-1/2" MPT)	35	9.8	20.3	8.8	1-1/8	2-1/8	2-1/2 MPT	142
CHN40 (2-1/2" MPT)	40	9.8	20.3	9.8	1-1/8	2-1/8	2-1/2 MPT	155
CHN50 (2-1/2" MPT)	50	9.8	20.3	12.6	1-1/8	2-5/8	2-1/2 MPT	193
CHN60 (2-1/2" MPT)	60	9.8	20.3	14.5	1-1/8	2-5/8	2-1/2 MPT	217
CHN70 (2-1/2" MPT)	70	9.8	20.3	16.4	1-1/8	2-5/8	2-1/2 MPT	241
CHN80 (2-1/2" MPT)	80	9.8	20.3	19.3	1-1/8	2-5/8	2-1/2 MPT	274

- Notes:
1. Design Pressure: 300psig, all CHN models
 2. Selected models available from stock. Non-stock models subject to 2-3 week lead time.
 3. Sweat connections on refrigerant side with MPT on liquid side.

CH-M Direct Expansion Evaporators

Manifolded Dx Evaporators

80 to 160 tons

For 80 to 160 ton chiller applications, the CH-M Series is the most compact design available for new system designs and ideal for shell & tube replacements. Comprised of two heat exchangers with a large common fluid side manifold, the CH-M Series can be ordered as a single (1), dual (2) or quad (4) refrigerant circuits. The CH-M Series is made with 316L stainless steel plates, copper brazed. Refrigerant side has sweat solder connections. Fluid side manifold and Flange connections are carbon steel, with optional stainless steel for potable water applications. Rated 450 psig refrigerant side and 150 psig Fluid side. CH-M models have individual modules that are U.L. Listed and optional ASME Code.

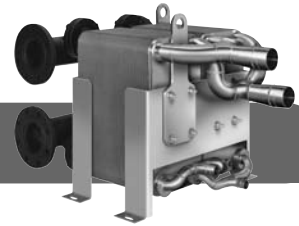

Single Circuit

Model	Tons	Width	Height	Depth	Refrig In	Refrig Out	Water	Net Wt. (lbs.)
CH80M-1C	80	25.5	24.0	34.1	1-5/8	2-5/8	4" flange	525
CH100M-1C	100	25.5	24.0	37.9	2-1/8	3-1/8	4" flange	670
CH120M-1C	120	25.5	24.0	41.6	2-1/8	3-1/8	4" flange	714
CH140M-1C	140	25.5	24.0	44.0	2-5/8	3-5/8	4" flange	802
CH160M-1C	160	25.5	24.0	46.3	2-5/8	3-5/8	5" flange	893

Dual Circuit

Model	Tons	Width	Height	Depth	Refrig In	Refrig Out	Water	Net Wt. (lbs.)
CH80M-2C	80	25.5	24.0	34.1	1-1/8	2-1/8	4" flange	525
CH100M-2C	100	25.5	24.0	37.9	1-1/8	2-1/8	4" flange	670
CH120M-2C	120	25.5	24.0	41.6	1-3/8	2-5/8	4" flange	714
CH140M-2C	140	25.5	24.0	44.0	1-5/8	2-5/8	4" flange	802
CH160M-2C	160	25.5	24.0	46.3	1-5/8	2-5/8	5" flange	893

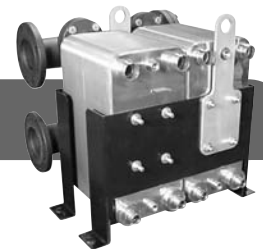

Quad Circuit

Model	Tons	Width	Height	Depth	Refrig In	Refrig Out	Water	Net Wt. (lbs.)
CH80M-4C	80	25.5	24.0	24.5	7/8	1-5/8	4" flange	383
CH100M-4C	100	25.5	24.0	28.3	1-1/8	1-5/8	4" flange	449
CH120M-4C	120	25.5	24.0	30.7	1-1/8	2-1/8	4" flange	493
CH140M-4C	140	25.5	24.0	33.1	1-1/8	2-1/8	4" flange	537
CH160M-4C	160	25.5	24.0	35.4	1-1/8	2-1/8	5" flange	628

- Notes:**
1. Nominal tons - 12,000 BTUH per ton, 54°F EWT, 44°LWT, 35°F Evap Temp, 6°F Superheat, 2.4 gpm per ton, R-22.
 2. For Glycol, special fluids or design conditions other than listed above, please contact the factory for special computer selection.
 3. Fluid side manifold piping is carbon steel material. Fluid temperatures on the process side below -20°F (-29°C) require stainless steel manifold piping. Please consult your sales representative or the factory for availability.

- Options:**
1. For fittings and configurations other than standard, consult the factory for pricing.
 2. For ASME code version, the model number should include "-UM". Example CH80M-2C-UM. ASME code approval does not apply to the manifold piping. BPHE units are ASME code stamped individually.
 3. Stainless steel manifold assemblies available for potable water applications.

Condenser/Heat Pumps

C Series

1/2 to 80 tons



FlatPlate® C Series condenser/heat pump models' compact design reduces size without sacrificing efficiency. They are designed for use with R-22, R-134a, R-404a and other halocarbon refrigerants. Select models can be used for heat pump applications. All C Series models are constructed from copper brazed 316L stainless steel plates and come in sizes from 1/2 to 80 tons. All units are rated at 450 psig working pressure on both refrigerant side and water side. The C Series is UL listed. ASME and/or CE certification is optional.

5" x 12" Models

Model	Tons	Application ¹	Width	Length	Depth	Refrig In	Refrig Out	Water	Net Wt. (lbs.)
C1/2A	.5	Condenser/Heat Pump	4.9	12.2	1.1	5/8 ID	5/8 ID	7/8 ID	6
C3/4A	.75	Condenser/Heat Pump	4.9	12.2	1.3	5/8 ID	5/8 ID	7/8 ID	7
C1A	1	Condenser/Heat Pump	4.9	12.2	1.5	5/8 ID	5/8 ID	7/8 ID	7
C1-1/2A	1.5	Condenser/Heat Pump	4.9	12.2	1.9	5/8 ID	5/8 ID	7/8 ID	9
C2A	2	Condenser/Heat Pump	4.9	12.2	2.2	5/8 ID	5/8 ID	7/8 ID	10
C2-1/2A	2.5	Condenser/Heat Pump	4.9	12.2	2.6	5/8 ID	5/8 ID	7/8 ID	11
C3A	3	Condenser/Heat Pump	4.9	12.2	3.2	5/8 ID	5/8 ID	7/8 ID	13
C3-1/2A	3.5	Condenser/Heat Pump	4.9	12.2	3.7	5/8 ID	5/8 ID	7/8 ID	15
C4A	4	Condenser/Heat Pump	4.9	12.2	4.5	7/8 ID	5/8 ID	1-1/8 ID	18
C5A	5	Condenser ²	4.9	12.2	5.4	7/8 ID	5/8 ID	1-1/8 ID	21

5" x 20" Models

Model	Tons	Application ¹	Width	Length	Depth	Refrig In	Refrig Out	Water	Net Wt. (lbs.)
C2	2	Condenser/Heat Pump	4.9	20.3	1.3	5/8 ID	5/8 ID	7/8 ID	11
C2-1/2	2.5	Condenser/Heat Pump	4.9	20.3	1.5	5/8 ID	5/8 ID	7/8 ID	13
C3	3	Condenser/Heat Pump	4.9	20.3	1.7	5/8 ID	5/8 ID	7/8 ID	14
C3-1/2	3.5	Condenser/Heat Pump	4.9	20.3	1.9	5/8 ID	5/8 ID	7/8 ID	15
C4	4	Condenser/Heat Pump	4.9	20.3	2.1	7/8 ID	5/8 ID	1-1/8 ID	16
C5	5	Condenser/Heat Pump	4.9	20.3	2.4	7/8 ID	5/8 ID	1-1/8 ID	18
C6	6	Condenser/Heat Pump	4.9	20.3	2.6	7/8 ID	5/8 ID	1-1/8 ID	19
C7-1/2	7.5	Condenser/Heat Pump	4.9	20.3	3.2	1-1/8 ID	7/8 ID	1-1/8 ID	24
C10	10	Condenser/Heat Pump	4.9	20.3	4.1	1-1/8 ID	7/8 ID	1-3/8 ID	28
C12B	12.5	Condenser ²	4.9	20.3	5.1	1-3/8 ID	7/8 ID	1-3/8 ID	34
C15B	15	Condenser ²	4.9	20.3	6.0	1-3/8 ID	7/8 ID	1-3/8 ID	40

10" x 20" Models

Model	Tons	Application ¹	Width	Length	Depth	Refrig In	Refrig Out	Water	Net Wt. (lbs.)
C10C	10	Condenser/Heat Pump	9.8	20.3	2.2	1-3/8 ID	7/8 ID	1-5/8 ID	33
C12	12.5	Condenser/Heat Pump	9.8	20.3	2.6	1-3/8 ID	7/8 ID	1-5/8 ID	38
C15	15	Condenser/Heat Pump	9.8	20.3	3.2	1-3/8 ID	7/8 ID	1-5/8 ID	44
C20	20	Condenser ²	9.8	20.3	4.1	1-5/8 ID	1-1/8 ID	1-5/8 ID	55
C25	25	Condenser ²	9.8	20.3	5.1	1-5/8 ID	1-1/8 ID	2-1/8 ID	66
C30	30	Condenser ²	9.8	20.3	6.0	2-1/8 ID	1-1/8 ID	2-1/8 ID	77
C35	35	Condenser ²	9.8	20.3	6.9	2-1/8 ID	1-3/8 ID	2-5/8 ID	88
C40	40	Condenser ²	9.8	20.3	7.9	2-1/8 ID	1-3/8 ID	2-5/8 ID	99
C50	50	Condenser ²	9.8	20.3	9.8	2-1/8 ID	1-5/8 ID	2-5/8 ID	121
C60	60	Condenser ²	9.8	20.3	11.6	2-1/8 ID	1-5/8 ID	2-5/8 ID	143
C70	70	Condenser ²	9.8	20.3	13.5	2-1/8 ID	1-5/8 ID	2-5/8 ID	165
C80	80	Condenser ²	9.8	20.3	15.5	2-1/8 ID	1-5/8 ID	2-5/8 ID	183

- Notes:**
1. Nominal tons - 15,000 BTUH per ton, 85°F EWT, 105°F Condensing Temp, 3 gpm per ton, R-22.
 2. For Heat Pump application, contact the factory for specific heat pump model.
 3. For City Water application 75°F EWT, 105°F Condensing Temp, 3 gpm per ton, multiply unit nominal capacity by 1.59.
 4. For R410a condenser application, contact the factory for 600 psig models.

- Options:**
1. For fittings and configurations other than standard, consult the factory for pricing.
 2. For ASME code version, the model number should include "-UM". Example C40-UM
 3. For R-410a applications, the model number should include "-XP". Example C40-XP

C-M Condensers

Manifolded Condensers

80 to 160 tons

C-M Condensers

For 80 to 160 ton condenser applications, the C-M Series is the most compact available for new system designs and ideal for shell & tube replacements. Comprised of two heat exchangers with a large common fluid side manifold, the C-M Series can be ordered as a single (1), dual (2) or quad (4) refrigerant circuits. The C-M Series is made with 316L stainless steel plates, copper brazed. Refrigerant side has sweat solder connections. Fluid side manifold and Flange connections are carbon steel, with optional stainless steel for potable water applications. Rated 450 psig refrigerant side and 150 psig Fluid side. C-M models have individual modules that are U.L. Listed and optional ASME Code.

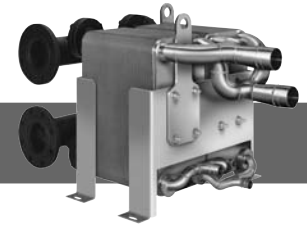

Single Circuit

Model	Tons	Width	Height	Depth	Refrig In	Refrig Out	Water	Net Wt. (lbs.)
C80M-1C	80	25.5	24.0	29.8	2-5/8	1-5/8	4" flange	481
C100M-1C	100	25.5	24.0	31.7	2-5/8	1-5/8	4" flange	604
C120M-1C	120	25.5	24.0	36.9	3-1/8	2-1/8	5" flange	648
C140M-1C	140	25.5	24.0	38.2	3-1/8	2-1/8	5" flange	736
C160M-1C	160	25.5	24.0	40.7	3-1/8	2-1/8	5" flange	827

Dual Circuit

Model	Tons	Width	Height	Depth	Refrig In	Refrig Out	Water	Net Wt. (lbs.)
C80M-2C	80	25.5	24.0	29.8	2-1/8	1-1/8	4" flange	481
C100M-2C	100	25.5	24.0	31.7	2-1/8	1-1/8	4" flange	604
C120M-2C	120	25.5	24.0	36.9	2-5/8	1-3/8	5" flange	648
C140M-2C	140	25.5	24.0	38.2	2-5/8	1-5/8	5" flange	736
C160M-2C	160	25.5	24.0	40.7	2-5/8	1-5/8	5" flange	827

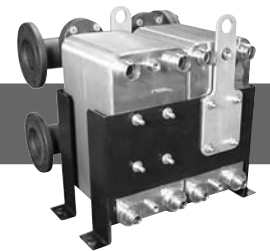

Quad Circuit

Model	Tons	Width	Height	Depth	Refrig In	Refrig Out	Water	Net Wt. (lbs.)
C80M-4C	80	25.5	24.0	22.5	1-5/8	7/8	4" flange	339
C100M-4C	100	25.5	24.0	25.3	1-5/8	1-1/8	4" flange	383
C120M-4C	120	25.5	24.0	27.7	2-1/8	1-1/8	5" flange	427
C140M-4C	140	25.5	24.0	30.1	2-1/8	1-1/8	5" flange	471
C160M-4C	160	25.5	24.0	32.4	2-1/8	1-1/8	5" flange	562

- Notes:**
1. Nominal tons - 15,000 BTUH per ton, 85°F EWT, 105°F Condensing Temp, 3 gpm per ton, R-22.
 2. For Glycol, special fluids or design conditions other than listed above, please contact the factory for special computer selection.

- Options:**
1. For fitting and configurations other than standard, consult the factory for pricing.
 2. For ASME code version, the model number should include "-UM". Example C80M-2C-UM. ASME code approval does not apply to the manifold piping. BPHE units are ASME code stamped individually.
 3. Stainless steel manifold assemblies available for potable water applications.

Industrial Condensers

MCN Series

1/2 to 80 tons



FlatPlate® MCN Industrial Refrigeration Condensers are designed for Brackish water, chlorinated and swimming pool water and fluids with corrosion potential or micro-biological elements. MCN models are compact workhorses for applications up to 80 tons. All models are fabricated from nickel brazed marine grade stainless steel with stainless steel sweat connections on the refrigerant side (front) and female pipe thread connections on the fluid side (rear). Zinc anode and anode fitting included.

Condenser Model	Tons(1) 110F Ct	Tons(2) 110F Ct	Tons(3) 105F Ct	Tons(4) 105F Ct	Width	Length	Depth	Refrigerant Connections		Water	Max Flow gpm	Weight lbs
								In	Out			
5"x12" Models												
MCN1/2A	1	0.8	0.8	0.5	4.9	12.2	1.3	5/8	5/8	3/4"FPT	15	14
MCN3/4A	1.5	1.1	1.1	0.75	4.9	12.2	1.5	5/8	5/8	3/4"FPT	15	16
MCN1A	2	1.5	1.4	1	4.9	12.2	1.7	5/8	5/8	3/4"FPT	15	16
MCN1-1/2A	3	2.3	2.1	1.5	4.9	12.2	2	5/8	5/8	3/4"FPT	15	17
MCN2A	4	3	2.9	2	4.9	12.2	2.4	5/8	5/8	3/4"FPT	15	18
MCN2-1/2A	5	3.8	3.6	2.5	4.9	12.2	2.5	5/8	5/8	1"FPT	40	20
MCN3A	6	4.5	4.3	3	4.9	12.2	3.2	5/8	5/8	1"FPT	40	22
MCN3-1/2A	7	5.3	5	3.5	4.9	12.2	3.7	5/8	5/8	1"FPT	40	23
MCN4A	8	6	5.7	4	4.9	12.2	4.4	7/8	5/8	1"FPT	40	25
MCN5A	10	7.6	7.1	5	4.9	12.2	5.3	7/8	5/8	1"FPT	40	29
MCN7-1/2A	15	13.3	11.8	7.5	4.9	12.2	7.5	1-1/8	7/8	1-1/4"FPT	60	32
MCN10A	20	15.5	14.1	10	4.9	12.2	10	1-1/8	7/8	1-1/4"FPT	60	36
10"x20" Models												
MCN10L	15	12	12	10	9.8	20.3	2.6	1-5/8	1-1/8	1-1/2"FPT	100	75
MCN12L	19	15	15	12	9.8	20.3	3.2	1-5/8	1-1/8	1-1/2"FPT	100	83
MCN15L	24	18	19	15	9.8	20.3	3.7	1-5/8	1-1/8	1-1/2"FPT	100	90
MCN20L	32	26	26	20	9.8	20.3	5.1	1-5/8	1-1/8	1-1/2"FPT	100	108
MCN25L	40	31	31	25	9.8	20.3	6	1-5/8	1-1/8	2"FPT	100	121
MCN30L	48	37	37	30	9.8	20.3	6.9	2-1/8	1-3/8	2"FPT	200	134
MCN35L	56	44	44	35	9.8	20.3	7.9	2-1/8	1-3/8	2"FPT	200	146
MCN40L	64	50	50	40	9.8	20.3	8.8	2-1/8	1-3/8	2"FPT	200	159
MCN50L	78	61	61	50	9.8	20.3	10.7	2-1/8	1-5/8	2"FPT	200	185
MCN60L	96	75	75	60	9.8	20.3	13.5	2-1/8	1-5/8	2"FPT	250	223
MCN70L	112	87	87	70	9.8	20.3	16.3	2-1/8	1-5/8	2"FPT	250	261
MCN75L	120	94	94	75	9.8	20.3	18.2	2-1/8	1-5/8	2"FPT	250	287

- NOTES:**
1. Nominal tons @ 110F Ct = 15,000 Btu/Hr per ton, 85F EWT, 110F condensing temperature, 5 gpm per ton.
 2. Nominal tons @ 110F Ct = 15,000 Btu/Hr per ton, 85F EWT, 110F condensing temperature, 3 gpm per ton.
 3. Nominal tons @ 105F Ct = 15,000 Btu/Hr per ton, 85F EWT, 105F condensing temperature, 5 gpm per ton.
 4. Nominal tons @ 105F Ct = 15,000 Btu/Hr per ton, 85F EWT, 105F condensing temperature, 3 gpm per ton.
 5. Designed for Brackish Water, Swimming Pool Water, < 5 Ph, and water with chlorides and other corrosive properties.
 6. For city water applications, 75F Ewt, 105F condensing temperature, 3 gpm per ton, multiply unit nominal capacity at 105F Ct by 1.59.
 7. Materials: Marine Stainless, Nickel Brazed.
 8. Zinc Anode & Fitting Built-In. Anode required for swimming pools with electronic chlorinators.
 9. The MCN model is not recommended for shipboard seawater duty, or applications where electrical potentials may cause galvanic corrosion.

Subcoolers and Specials

SC Series

1 to 120 tons



As the smallest, most cost effective subcooler available, FlatPlate® SC Series is a strong performer in supermarket, food process and other low temperature installations. Use a FlatPlate® SC model subcooler where subcooled liquid refrigerant is needed to improve overall system efficiency, increase coil capacity and eliminate liquid line bubbles. The SC Series has Sweat connections, properly sized for liquid lines. All models have a built-in DX distributor for stable expansion valve operation and capacity control. Constructed of copper brazed 316L stainless steel plates. Rated working pressure 450 psig. All models are UL listed. Optional ASME and European PED CE Approval.

5" x 12" Models

Model	Tons ¹	Application	Width	Length	Depth	Refrig Out	Refrig In	Liquid In/Out	Net Wt. (lbs.)
SC1	1	Subcooler	4.9	12.2	1.1	7/8 ID	5/8 ID	1-1/8 ID	6.0
SC2	2	Subcooler	4.9	12.2	1.5	7/8 ID	5/8 ID	1-1/8 ID	7.0
SC3	3	Subcooler	4.9	12.2	1.9	7/8 ID	5/8 ID	1-1/8 ID	9.0
SC5	5	Subcooler	4.9	12.2	2.4	1-1/8 ID	7/8 ID	1-1/8 ID	11.0
SC7	7	Subcooler	4.9	12.2	3.2	1-1/8 ID	7/8 ID	1-1/8 ID	13.0
SC10	10	Subcooler	4.9	12.2	4.1	1-3/8 ID	7/8 ID	1-3/8 ID	16.0
SC12	12	Subcooler	4.9	12.2	5.1	1-3/8 ID	7/8 ID	1-3/8 ID	19.0
SC14	14	Subcooler	4.9	12.2	6.0	1-3/8 ID	7/8 ID	1-3/8 ID	23.0

10" x 20" Models

Model	Tons ¹	Application	Width	Length	Depth	Refrig Out	Refrig In	Liquid In/Out	Net Wt. (lbs.)
SC16	16	Subcooler	9.8	20.3	2.3	1-5/8 ID	1-1/8 ID	2-1/8 ID	33
SC22	22	Subcooler	9.8	20.3	3.2	1-5/8 ID	1-1/8 ID	2-1/8 ID	44
SC28	28	Subcooler	9.8	20.3	4.1	2-1/8 ID	1-1/8 ID	2-5/8 ID	55
SC35	35	Subcooler	9.8	20.3	5.1	2-1/8 ID	1-1/8 ID	2-5/8 ID	66
SC42	42	Subcooler	9.8	20.3	6.0	2-1/8 ID	1-1/8 ID	2-5/8 ID	77
SC54	54	Subcooler	9.8	20.3	7.9	2-5/8 ID	1-1/8 ID	2-5/8 ID	88
SC66	66	Subcooler	9.8	20.3	9.8	2-5/8 ID	1-1/8 ID	2-5/8 ID	121
SC80	80	Subcooler	9.8	20.3	11.6	2-5/8 ID	1-1/8 ID	2-5/8 ID	155
SC90	90	Subcooler	9.8	20.3	13.5	2-5/8 ID	1-3/8 ID	2-5/8 ID	165
SC100	100	Subcooler	9.8	20.3	14.5	2-5/8 ID	1-5/8 ID	2-5/8 ID	176
SC120	120	Subcooler	9.8	20.3	16.3	2-5/8 ID	1-5/8 ID	2-5/8 ID	198

Note: 1. Design Conditions: Liquid Refrigerant Subcooled from 110°F to 50°F, 35°F Etp R22 or R404a.

Nickel Brazed Models

FlatPlate® manufactures a complete line of "NICKEL BRAZED" versions of all models in this catalog. Applicable where the fluid(s) are not compatible with copper, such as; Low PH ground water, Solvents, De-ionized Water, and Ammonia Refrigeration. **FOR NICKEL BRAZED VERSIONS, SEE CHN SERIES, FPN AND MPN SERIES, OR CONTACT THE FACTORY FOR NH3 VERSION.**



Special Applications

Brazed Plate heat exchangers can be used in a wide variety of refrigeration designs, including low temperature applications, high viscosity fluids, and many more. Standard and custom units can be computer selected by FlatPlate® application department. The following is a partial list of other refrigeration applications:

Application	Conditions
GLYCOL CHILLERS	to -50°F fluid chillers
OIL COOLERS	for compressor or/and hydraulic oil coolers
ULTRA LOWTEMP CHILLERS	to -100°F chillers
CRYOGENIC CHILLERS	to -320°F using liquid Nitrogen
GAS DRIERS	from 30 SCFM to 5000 SCFM
HYDROCARBON PROCESSES	from +100°F to -320°F
CASCADE CONDENSERS	for environmental chambers and low temp chillers
DESUPERHEATERS	for water heating or 2 stage compressor cooling
NEW REFRIGERANTS	R134a, R410a, R404a, AZ20, R407c AND OTHERS
SPECIAL FLUIDS	Call the factory

Fluid to Fluid

FP Series - Hydronic

1/2 to 200 GPM



FlatPlate® FP Series is designed for a wide variety of fluid to fluid applications such as process separation, high pressure system isolation, fluid cooling with chilled water, oil cooling, hydronic heating, domestic water heating and close approach (as low as 3 deg. F for the larger models) situations. All FP Series models are constructed from copper brazed 316L stainless steel plates with stainless steel MPT connections and mounting studs as standard. The configuration of FlatPlate® high efficient heat transfer surface minimizes fouling, even in hard water conditions. All models are rated at 450 psig pressure on both sides. The FP Series is UL Listed, with ASME code and/or European CE code optional.

5"x12" Models FP	Connections	Plates	Width	Length	Depth	GPM@5.0psi PD		Approx. Wt. Net (lbs.)
						Side A	Side B	
FP5X12-4 (3/4" MPT)	3/4" MPT	4	4.9	12.2	0.7	3.2	5.8	4.6
FP5X12-6 (3/4" MPT)	3/4" MPT	6	4.9	12.2	0.9	6.3	8.8	5.1
FP5X12-8 (3/4" MPT)	3/4" MPT	8	4.9	12.2	1.1	9.4	11.6	5.8
FP5X12-10 (3/4" MPT)	3/4" MPT	10	4.9	12.2	1.3	6.3	7.9	6.4
FP5X12-12 (3/4" MPT)	3/4" MPT	12	4.9	12.2	1.5	7.9	9.4	7.0
FP5X12-14 (3/4" MPT)	3/4" MPT	14	4.9	12.2	1.7	9.5	11.0	7.7
FP5X12-16 (3/4" MPT)	3/4" MPT	16	4.9	12.2	1.9	11.0	12.6	8.3
FP5X12-20 (1" MPT)	1" MPT	20	4.9	12.2	2.2	14.1	15.5	9.6
FP5X12-24 (1" MPT)	1" MPT	24	4.9	12.2	2.6	17.1	18.5	10.8
FP5X12-30 (1" MPT)	1" MPT	30	4.9	12.2	3.2	21.5	22.9	12.7
FP5X12-30 (1-1/4" MPT)	1-1/4" MPT	30	4.9	12.2	3.2	25.0	26.4	12.7
FP5X12-36 (1" MPT)	1" MPT	36	4.9	12.2	3.7	25.8	27.0	14.6
FP5X12-40 (1" MPT)	1" MPT	40	4.9	12.2	4.1	28.5	29.7	15.9
FP5X12-40 (1-1/4" MPT)	1-1/4" MPT	40	4.9	12.2	4.1	32.0	33.2	15.9
FP5X12-50 (1" MPT)	1" MPT	50	4.9	12.2	5.1	34.8	35.8	19.0
FP5X12-50 (1-1/4" MPT)	1-1/4" MPT	50	4.9	12.2	5.1	38.3	39.3	19.0
FP5X12-60 (1-1/4" MPT)	1-1/4" MPT	60	4.9	12.2	6.0	40.2	41.2	22.2
FP5X12-70 (1-1/4" MPT)	1-1/4" MPT	70	4.9	12.2	6.9	45.0	46.0	25.3
FP5X12-80 (1-1/4" MPT)	1-1/4" MPT	80	4.9	12.2	7.9	49.8	50.4	28.5
10"x20" Models FP	Connections	Plates	Width	Length	Depth	GPM@7.5psi PD		Approx. Wt. Net/Ship (lbs.)
						Side A	Side B	
FP10X20-20 (1-1/2" MPT)	1-1/2" MPT	20	9.8	20.3	2.2	27.6	30.5	33
FP10X20-24 (1-1/2" MPT)	1-1/2" MPT	24	9.8	20.3	2.6	33.6	36.5	37
FP10X20-30 (1-1/2" MPT)	1-1/2" MPT	30	9.8	20.3	3.2	42.7	45.5	44
FP10X20-36 (1-1/2" MPT)	1-1/2" MPT	36	9.8	20.3	3.7	51.5	54.5	50
FP10X20-40 (1-1/2" MPT)	1-1/2" MPT	40	9.8	20.3	4.1	57.5	60.3	55
FP10X20-50 (2" MPT)	2" MPT	50	9.8	20.3	5.1	71.8	74.5	66
FP10X20-60 (2" MPT)	2" MPT	60	9.8	20.3	6.0	85.5	88.3	77
FP10X20-70 (2" MPT)	2" MPT	70	9.8	20.3	6.9	99	101	88
FP10X20-80 (2" MPT)	2" MPT	80	9.8	20.3	7.9	112	114	99
FP10X20-90 (2-1/2" MPT)	2-1/2" MPT	90	9.8	20.3	8.8	123	125	110
FP10X20-100 (2-1/2" MPT)	2-1/2" MPT	100	9.8	20.3	9.8	135	137	121
FP10X20-110 (2-1/2" MPT)	2-1/2" MPT	110	9.8	20.3	10.7	146	148	132
FP10X20-120 (2-1/2" MPT)	2-1/2" MPT	120	9.8	20.3	11.6	155	157	143
FP10X20-130 (2-1/2" MPT)	2-1/2" MPT	130	9.8	20.3	12.6	165	167	154
FP10X20-140 (2-1/2" MPT)	2-1/2" MPT	140	9.8	20.3	13.5	174	176	165
FP10X20-150 (2-1/2" MPT)	2-1/2" MPT	150	9.8	20.3	14.5	183	184	176
FP10X20-160 (2-1/2" MPT)	2-1/2" MPT	160	9.8	20.3	15.4	191	192	187
FP10X20-170 (2-1/2" MPT)	2-1/2" MPT	170	9.8	20.3	16.3	198	199	198
FP10X20-180 (2-1/2" MPT)	2-1/2" MPT	180	9.8	20.3	17.3	205	206	209
FP10X20-190 (2-1/2" MPT)	2-1/2" MPT	190	9.8	20.3	18.2	211	212	220
FP10X20-200 (2-1/2" MPT)	2-1/2" MPT	200	9.8	20.3	19.2	217	218	231

For ASME code, add "-UM" after the model number. Example: FP10x20-80 (2" MPT)-UM

Fluid to Fluid

FPN Series - All Stainless, Nickel Brazed

1/2 to 200 GPM



FlatPlate® FPN Series of fluid to fluid nickel brazed heat exchangers were developed for heat transfer applications where 316L stainless steel offers adequate corrosion resistance but copper is not compatible with one or both liquids involved in the heat transfer process. The FPN Series is recommended for use with de-ionized water, wines and beverages, and solvents. Performance characteristics match those of FlatPlate® FP Series copper brazed models. All models are 300 psig working pressure, both sides. UL Listed. ASME and CE certification optional.

5"x12" Models FP	Connections	Plates	Width	Length	Depth	GPM@5.0psi PD		Approx. Wt. Net (lbs.)
						Side A	Side B	
FPN5X12-4 (3/4" MPT)	3/4" MPT	4	4.9	12.2	0.7	3.2	5.8	4.6
FPN5X12-6 (3/4" MPT)	3/4" MPT	6	4.9	12.2	0.9	6.3	8.8	5.1
FPN5X12-8 (3/4" MPT)	3/4" MPT	8	4.9	12.2	1.1	9.4	11.6	5.8
FPN5X12-10 (3/4" MPT)	3/4" MPT	10	4.9	12.2	1.3	6.3	7.9	6.4
FPN5X12-12 (3/4" MPT)	3/4" MPT	12	4.9	12.2	1.5	7.9	9.4	7.0
FPN5X12-14 (3/4" MPT)	3/4" MPT	14	4.9	12.2	1.7	9.5	11.0	7.7
FPN5X12-16 (3/4" MPT)	3/4" MPT	16	4.9	12.2	1.9	11.0	12.6	8.3
FPN5X12-20 (1" MPT)	1" MPT	20	4.9	12.2	2.2	14.1	15.5	9.6
FPN5X12-24 (1" MPT)	1" MPT	24	4.9	12.2	2.6	17.1	18.5	10.8
FPN5X12-30 (1" MPT)	1" MPT	30	4.9	12.2	3.2	21.5	22.9	12.7
FPN5X12-30 (1-1/4" MPT)	1-1/4" MPT	30	4.9	12.2	3.2	25.0	26.4	12.7
FPN5X12-36 (1" MPT)	1" MPT	36	4.9	12.2	3.7	25.8	27.0	14.6
FPN5X12-40 (1" MPT)	1" MPT	40	4.9	12.2	4.1	28.5	29.7	15.9
FPN5X12-40 (1-1/4" MPT)	1-1/4" MPT	40	4.9	12.2	4.1	32.0	33.2	15.9
FPN5X12-50 (1" MPT)	1" MPT	50	4.9	12.2	5.1	34.8	35.8	19.0
FPN5X12-50 (1-1/4" MPT)	1-1/4" MPT	50	4.9	12.2	5.1	38.3	39.3	19.0
FPN5X12-60 (1-1/4" MPT)	1-1/4" MPT	60	4.9	12.2	6.0	40.2	41.2	22.2
FPN5X12-70 (1-1/4" MPT)	1-1/4" MPT	70	4.9	12.2	6.9	45.0	46.0	25.3
FPN5X12-80 (1-1/4" MPT)	1-1/4" MPT	80	4.9	12.2	7.9	49.8	50.4	28.5
10"x20" Models FP	Connections	Plates	Width	Length	Depth	GPM@7.5psi PD		Approx. Wt. Net/Ship (lbs.)
						Side A	Side B	
FPN10X20-20 (1-1/2" MPT)	1-1/2" MPT	20	9.8	20.3	2.2	27.6	30.5	33
FPN10X20-24 (1-1/2" MPT)	1-1/2" MPT	24	9.8	20.3	2.6	33.6	36.5	37
FPN10X20-30 (1-1/2" MPT)	1-1/2" MPT	30	9.8	20.3	3.2	42.7	45.5	44
FPN10X20-36 (1-1/2" MPT)	1-1/2" MPT	36	9.8	20.3	3.7	51.5	54.5	50
FPN10X20-40 (1-1/2" MPT)	1-1/2" MPT	40	9.8	20.3	4.1	57.5	60.3	55
FPN10X20-50 (2" MPT)	2" MPT	50	9.8	20.3	5.1	71.8	74.5	66
FPN10X20-60 (2" MPT)	2" MPT	60	9.8	20.3	6.0	85.5	88.3	77
FPN10X20-70 (2" MPT)	2" MPT	70	9.8	20.3	6.9	99	101	88
FPN10X20-80 (2" MPT)	2" MPT	80	9.8	20.3	7.9	112	114	99
FPN10X20-90 (2-1/2" MPT)	2-1/2" MPT	90	9.8	20.3	8.8	123	125	110
FPN10X20-100 (2-1/2" MPT)	2-1/2" MPT	100	9.8	20.3	9.8	135	137	121
FPN10X20-110 (2-1/2" MPT)	2-1/2" MPT	110	9.8	20.3	10.7	146	148	132
FPN10X20-120 (2-1/2" MPT)	2-1/2" MPT	120	9.8	20.3	11.6	155	157	143
FPN10X20-130 (2-1/2" MPT)	2-1/2" MPT	130	9.8	20.3	12.6	165	167	154
FPN10X20-140 (2-1/2" MPT)	2-1/2" MPT	140	9.8	20.3	13.5	174	176	165
FPN10X20-150 (2-1/2" MPT)	2-1/2" MPT	150	9.8	20.3	14.5	183	184	176
FPN10X20-160 (2-1/2" MPT)	2-1/2" MPT	160	9.8	20.3	15.4	191	192	187
FPN10X20-170 (2-1/2" MPT)	2-1/2" MPT	170	9.8	20.3	16.3	198	199	198
FPN10X20-180 (2-1/2" MPT)	2-1/2" MPT	180	9.8	20.3	17.3	205	206	209
FPN10X20-190 (2-1/2" MPT)	2-1/2" MPT	190	9.8	20.3	18.2	211	212	220
FPN10X20-200 (2-1/2" MPT)	2-1/2" MPT	200	9.8	20.3	19.2	217	218	231

For ASME code, add "-UM" after the model number. Example: FPN10x20-80 (2" MPT)-UM

Fluid to Fluid

"M" Manifolded Series

200 to 400 gpm

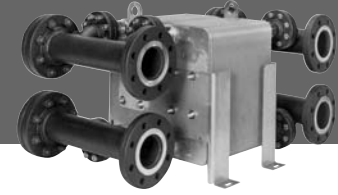

The FP-M Series is an ultra-compact, versatile unit designed for fluid to fluid applications up to 400 gpm and for practical use up to 2000 gpm with multiple units. One fifth the size of typical shell & tube heat exchangers, these models are space savers in large commercial and industrial applications. Large external manifolds allow easy piping for 4", 5" and 6" flange connections. All models use 316L Stainless Steel, copper brazed plates. Standard models use Carbon steel external piping manifolds rated for 150 psig. Higher working pressure versions available. Optional Stainless Steel manifolds and flanges. Individual modules are UL Listed and optional ASME stamped.

Model	No. of Plates	Connections (FLG)	GPM @ 9.5psi	Width (inches)	Length (inches)	Depth (inches)	Weight (lbs)
FP10X20-160M (4" Flg)	160	4"	224	24.6	42.8	33.9	520
FP10X20-200M (4" Flg)	200	4"	270	24.6	42.8	35.3	565
FP10X20-240M (4" Flg)	240	4"	310	24.6	42.8	39.2	650
FP10X20-280M (5" Flg)	280	5"	348	24.6	42.8	41.1	700
FP10X20-320M (5" Flg)	320	5"	382	24.6	42.8	42.9	750
FP10X20-360M (5" Flg)	360	5"	410	24.6	42.8	44.3	790
FP10X20-400M (5" Flg)	400	5"	440	24.6	42.8	46.7	825

- Notes:**
1. FP Models shown above rated for 150psig working pressure.
 2. Optional 300psig and 400psig versions.
 3. Fluid side manifold piping is carbon steel material not recommended for potable water. Stainless steel manifold assemblies available for potable water applications. Fluid temperatures on the process side below -20°F (-29°C) require stainless steel manifold piping. Please consult your sales representative or the factory for availability.
 4. Four versions available:
 FP and FP-L – 316L, copper brazed
 FPN – 316L, All Stainless, Nickel brazed
 MP-L – Marine Stainless, Nickel brazed
 5. For ASME code version, the model number should include "-UM". Example CH80M-2C-UM. ASME code approval does not apply to the manifold piping. BPHE units are ASME code stamped individually.



Fluid to Fluid

DW Series – DOUBLE WALL, VENTED

1 to 150 gpm

FlatPlate® DW Series is a Double Wall, Vented Heat Exchanger designed to meet local and state plumbing codes, and food process regulations that require double separation of potable water or food process fluids from glycols, boiler water and other non-potable fluids. As a full range Fluid to Fluid heat exchanger, the DW Series is a "True" double wall Vented design, with double wall plates, and double seal fluid ports, both of which have positive leak detection vents. The DW Series also has "Full Thickness" 316L stainless steel, copper brazed plates for longer life and reliability. Design working pressure 450 psig. UL Listed. Optional ASME.

<i>DW 10"x20" Models</i>	No. of Plates	Width (inches)	Length (inches)	Depth (inches)	Connections MPT	GPM @ 5 psig PD Side-A & B	Weight (lbs)
	DW10X20-6 (1" MPT)	6	9.8	20.3	1.0	1"	1.8
DW10X20-10 (1" MPT)	10	9.8	20.3	1.4	1"	3.7	22
DW10X20-14 (1" MPT)	14	9.8	20.3	1.8	1"	5.5	26
DW10X20-18 (1" MPT)	18	9.8	20.3	2.1	1"	7.5	31
DW10X20-22 (1" MPT)	22	9.8	20.3	2.5	1"	9.2	35
DW10X20-30 (1-1/4" MPT)	30	9.8	20.3	3.3	1-1/4"	12.1	44
DW10X20-42 (1-1/4" MPT)	42	9.8	20.3	4.4	1-1/4"	16.3	57
DW10X20-50 (1-1/2" MPT)	50	9.8	20.3	5.1	1-1/2"	19.2	66
DW10X20-62 (1-1/2" MPT)	62	9.8	20.3	6.3	1-1/2"	23.6	79
DW10X20-74 (1-1/2" MPT)	74	9.8	20.3	7.4	1-1/2"	28.0	92
DW10X20-94 (2" MPT)	94	9.8	20.3	9.3	2"	35.1	114
DW10X20-110 (2" MPT)	110	9.8	20.3	10.8	2"	40.9	132
DW10X20-134 (2" MPT)	134	9.8	20.3	13.0	2"	49.7	158
DW10X20-154 (2" MPT)	154	9.8	20.3	14.9	2"	57.2	180
DW10X20-198 (2" MPT)	198	9.8	20.3	19.0	2"	73.3	229

Refrigeration versions of the DW Series are available.

Fluid to Fluid

MPN Series - Swimming Pool, Steam, Industrial Process

1/2 to 200 GPM



FlatPlate® MPN Series is designed specifically for swimming pool applications, where chlorine, biological elements or low concentrations of acids are present. The MPN Series is rugged, yet very compact, representing the latest technology in aggressive environment duty plate heat exchangers. Its nickel brazed, marine stainless alloy plates offer significant improvements in reliability over traditional stainless materials and have high efficiency heat transfer for applications up to 60 gpm per unit. All MPN Series models have male pipe thread fittings and mounting stud bolts. Rated for 300 psig.

MPN Series applications include:

Swimming Pool

- Swimming pool to boiler
- Swimming pool to heat pump water loop

Steam

- Steam to domestic water
- Steam to process

Process

- Brackish water
- Treated steam to fluid
- Steam condensate to fluid
- Cooling tower water
- Low acid concentrations

5x12 Models	Plates	Width	Length	Depth	Connections	GPM@5.0psi PD		GPM@7.5psi PD		Approx. Wt. Net/Ship(lbs.)
						Side A	Side B	Side A	Side B	
MPN5X12-4 (1" MPT)	4	4.9	12.2	0.7	1" MPT	1.1	2.1	1.6	3.1	14.7
MPN5X12-6 (1" MPT)	6	4.9	12.2	0.9	1" MPT	2.1	3.1	3.2	4.7	15.5
MPN5X12-8 (1" MPT)	8	4.9	12.2	1.0	1" MPT	3.2	4.2	4.8	6.4	16.2
MPN5X12-10 (1" MPT)	10	4.9	12.2	1.2	1" MPT	4.2	5.2	6.4	8.0	16.9
MPN5X12-16 (1" MPT)	16	4.9	12.2	1.7	1" MPT	7.3	8.3	11.1	12.7	19.1
MPN5X12-20 (1-1/4" MPT)	20	4.9	12.2	2.0	1" MPT	9.3	10.3	14.2	15.7	20.6
MPN5X12-24 (1-1/4" MPT)	24	4.9	12.2	2.4	1-1/4" MPT	11.3	12.3	17.3	18.7	22.1
MPN5X12-30 (1-1/4" MPT)	30	4.9	12.2	2.9	1-1/4" MPT	16.6	17.5	25.3	26.7	24.3
MPN5X12-40 (1-1/4" MPT)	40	4.9	12.2	3.7	1-1/4" MPT	18.9	19.7	28.8	30.0	28.0
MPN5X12-50 (1-1/4" MPT)	50	4.9	12.2	4.6	1-1/4" MPT	25.4	26.0	38.7	39.7	31.6
MPN5X12-60 (1-1/4" MPT)	60	4.9	12.2	5.4	1-1/4" MPT	26.6	27.3	40.6	41.6	35.3
MPN5X12-70 (1-1/4" MPT)	70	4.9	12.2	6.3	1-1/4" MPT	29.8	30.5	45.5	46.5	39.0
MPN5X12-80 (1-1/4" MPT)	80	4.9	12.2	7.1	1-1/4" MPT	33.0	33.4	50.3	50.9	42.7

10x20 Models	Plates	Width	Length	Depth	Connections	GPM@5.0psi PD		GPM@7.5psi PD		Approx. Wt. Net/Ship(lbs.)
						Side A	Side B	Side A	Side B	
MPN10X20L-20 (1-1/2" MPT)	20	9.8	20.3	2.2	1-1/2" MPT	50.0	53.0	62.0	66.0	32.7
MPN10X20L-24 (1-1/2" MPT)	24	9.8	20.3	2.6	1-1/2" MPT	61.0	63.5	75.0	78.0	37.1
MPN10X20L-30 (2" MPT)	30	9.8	20.3	3.2	2" MPT	76.0	78.5	94.0	97.0	43.7
MPN10X20L-36 (2" MPT)	36	9.8	20.3	3.7	2" MPT	91.0	92.0	112.0	114.0	50.3
MPN10X20L-40 (2" MPT)	40	9.8	20.3	4.1	2" MPT	100.0	101.0	124.0	125.0	54.7
MPN10X20L-50 (2-1/2" MPT)	50	9.8	20.3	5.1	2-1/2" MPT	121.0	121.0	149.0	150.0	65.7
MPN10X20L-60 (2-1/2" MPT)	60	9.8	20.3	6.0	2-1/2" MPT	141.0	141.0	173.0	173.0	76.7
MPN10X20L-70 (2-1/2" MPT)	70	9.8	20.3	6.9	2-1/2" MPT	156.0	156.0	193.0	193.0	87.7
MPN10X20L-80 (2-1/2" MPT)	80	9.8	20.3	7.9	2-1/2" MPT	171.0	171.0	210.0	210.0	98.7
MPN10X20L-90 (2-1/2" MPT)	90	9.8	20.3	8.8	2-1/2" MPT	183.0	183.0	224.0	224.0	109.7
MPN10X20L-100 (2-1/2" MPT)	100	9.8	20.3	9.8	2-1/2" MPT	194.0	194.0	236.0	236.0	120.7

- NOTES:
1. All units are Industrial duty; swimming pool, brackish water, low PH water, ground water, river water, treated steam & condensate and select acids.
 2. Made with Marine Stainless Alloy, Nickel Brazed.
 3. Stainless steel MPT fittings and mounting stud bolts.
 4. Design Working Pressure: 300 psig.

Replacement Hx's – Refrigeration



FlatPlate® heat exchangers are easy replacement models for several import brands used in a wide range of HVAC/R equipment, supermarket systems and process chillers. Because FlatPlate® design is a “Next Generation” design, all FlatPlate® models meet or exceed performance and design pressure ratings of these models. Use the Selection Chart below,

Find the FlatPlate® Model which has the:

- 1) Closest model match, and
- 2) Design Applications/performance required, and
- 3) Approximate Unit dimensions

Selection Table

GEA FlatPlate Model	Replaces SWEF Model	Replaces ALFA-LAVAL Model
Liquid Chillers		
CH3x8-14	E5 or B5-14	CB14-14
CH3x8-20	E5 or B5-20	CB14-20
CH3x8-30	E5 or B5-30	CB14-30
CH3/4A	B10*10 & B8*20	CB25 & CB26-12
CH1A	B10*16 & B8*30	CB25 & CB26-14
CH2A	B10*20	CB25 & CB26-24
CH3A	B10*30	CB25 & CB26-34
CH3-1/2A	B10*40	CB25 & CB26-44
CH2	B15*20 & B25*10	CB50 & CB51-14
CH3	B15*30 & B25*20	CB50 & CB51-20
CH4	B25*26 & B15*40	CB50 & CB51-26
CH5	B25*30 & V27*30	CB50 & CB51-30
CH7-1/2	V27*40 & B25*50	CB50 & CB51-50
CH10B	V27*50	
CH10	V45*30 & V50*30	CB75 & CB76-30HX
CH15	V45*40 & V50*40	CB75 & CB76-40HX
CH20	V45*50 & V50*50	CB75 & CB76-50HX
CH25	V45*70 & V50*70	CB75 & CB76-70HX
CH30	V45*80 & V50*80	CB75 & CB76-80HX
CH40	V45*100, V45*130, V50*130	CB75 AND CB76-100HX
Condenser/Heat Pumps		
C1A	B8*20 & B10*16	CB25 & CB26-16
C2A	B8*30 & B10*20	CB25 & CB26-20
C3A	B8*50 & B10*30	CB25 & CB26-30
C2	B15*20	CB50 & CB51-14
C3	B15*30 & B25*16	CB50 & CB51-16
C4	B15*50 & B25*20	CB50 & CB51-20
C5	B15*60 & B25*26	CB50 & CB51-26
C7-1/2	B25*30	CB50 & CB51-30
C10	B25*40	CB50 & CB51-40
C10C	B45*20 & B35*40	CB75 & CB76-20
C15	B45*30 & B35*24	CB75 & CB76-30
C20	B45*40 & B35*30	CB75 & CB76-40
C25	B45*50 & B35*40	CB75 & CB76-50
C30	B45*60 & B35*50	CB75 & CB76-60

Dimensional Fit

For replacement applications, check the dimensional fit for the following units which maybe slightly larger or smaller than the unit it is replacing.

- B5, E5, CB14 models are 2.7"W x 8"H, to be replaced with a FlatPlate® 3x8 model, 3.3"W x 7.8"H
- B10, CB25, CB26 models are, 4.0"- 4.5"W x 12"H, to be replaced with a FlatPlate® 5x12 model, 4.9"W x 12"H
- B45, B50 models are, 9.5"-10"W x 20"H, to be replaced with a FlatPlate® 10x20 model, 9.8"W x 20"H
- CB75, CB76 models are 7.5"W x 24.5"H to be replaced with a FlatPlate® 10x20 model, 9.8"W x 20"H

Pressure Rating

All FlatPlate® FP series models are rated for 450 psig, equal to or greater than the units listed above. FlatPlate® MPN marine models can be substituted at 300 psig rating.

Failure Analysis

If the unit being replaced has been in service for less than 5 years (Plate Heat Exchanger or Shell & Tube), the cause or mode of failure may repeat itself, due to water quality, and other factors.

An MPN Marine Series unit is recommended for units being replaced that have been in service less than 5 years.

A failure analysis report can be performed by FlatPlate® for non-FlatPlate® models, for a nominal cost, as part of a replacement heat exchanger order.

Replacement Hx's – Fluid to Fluid



FlatPlate® heat exchangers are easy replacement models for several import brands used in a wide range of HVAC/R equipment. Because FlatPlate® design is a "Next Generation" design, all FlatPlate® models meet or exceed performance and design pressure ratings of these models. **Use the Selection Chart below,**

Find the FlatPlate® Model which has the:

- 1) Closest model match, and
- 2) Design Applications/performance required, and
- 3) Approximate Unit dimensions

REPLACEMENT HX'S - Selection Table

Fluid to Fluid

<i>GEA FlatPlate Models</i>	Replaces SWEP, Elge Models	Replaces ALFA-LAVAL Models	Replaces Triangle & Weil McLain Models
FP3X8-14 (3/4" MPT)	B5*14	CB12-14 and CB14-14	TTP1-14E and WMBP1-14E
FP3X8-20 (3/4" MPT)	B5*20	CB12-20 and CB14-20	TTP1-20E and WMBP1-20E
FP3X8-30 (3/4" MPT)	B5*30	CB12-30 and CB14-30	TTP1-30E and WMBP1-30E
FP5X12L-4 (3/4" MPT)	B8*10	CB25-6 and CB26-6	TTP1-14E and WMBP1-14E
FP5X12L-6 (3/4" MPT)	B8*10	CB25-8 and CB26-8	TTP1-14E and WMBP1-14E
FP5X12L-8 (3/4" MPT)	B8*16	CB25-12 and CB26-12	TTP1-20E and WMBP1-20E, TTP3-14 and WMBP3-14
FP5X12-10 (3/4" MPT)	B8*20	CB25-14 and CB26-14	TTP4-10 and WMBP4-10
FP5X12-12 (3/4" MPT)	B8*20	CB25-16 and CB26-16	TTP1-30E and WMBP1-30E, TTP3-20 and WMBP3-20
FP5X12-14 (3/4" MPT)	B5*36 and B10*20	CB25-16 and CB26-16	TTP4-14 and WMBP4-14
FP5X12-16 (3/4" MPT)	B8*24	CB25-24 and CB26-24	TTP3-40 and WMBP3-40, TTP4-14 and WMBP4-14
FP5X12-20 (1" MPT)	B8*36 and B10*30	CB25-28 and CB26-28	TTP3-40 and WMBP3-40
FP5X12-24 (1" MPT)	B8*40 and B10*30	CB25-34 and CB26-34	TTP4-24 and WMBP4-24
FP5X12-30 (1" MPT)	B10*40	CB25-44 and CB26-44	TTP4-30 and WMBP4-30
FP5X12-40 (1" MPT)	B10*50	CB25-54 and CB26-54	Not Available
FP5X12-50 (1" MPT)	B10*60	CB25-64 and CB26-64	TTP4-50 and WMBP4-50
FP10X20-20 (1-1/2" MPT)	B45*20 and B50*20	CB75*20 and CB76*20	TTP7-20 and WMBP7-20
FP10X20-24 (1-1/2" MPT)	B45*24 and B50*24	CB75*24 and CB76*24	TTP7-24 and WMBP7-24
FP10X20-30 (1-1/2" MPT)	B45*30 and B50*30	CB75*30 and CB76*30	TTP7-30 and WMBP7-30
FP10X20-40 (1-1/2" MPT)	B45*40 and B50*40	CB75*40 and CB76*40	TTP7-40 and WMBP7-40
FP10X20-50 (2" MPT)	B45*50 and B50*50	CB75*50 and CB76*50	TTP7-50 and WMBP7-50
FP10X20-60 (2" MPT)	B45*60 and B50*60	CB75*60 and CB76*60	TTP7-60 and WMBP7-60
FP10X20-70 (2" MPT)	B45*70 and B50*70	CB75*70 and CB76*70	TTP7-70 and WMBP7-70
FP10X20-80 (2" MPT)	B45*80 and B50*80	CB75*80 and CB76*80	TTP7-80 and WMBP7-80

For Larger Models contact your local GEA FlatPlate representative.

Dimensional Fit

For replacement applications, check the dimensional fit for the following units which maybe slightly larger or smaller than the unit it is replacing.

B5, E5, CB14 models are 2.7"W x 8"H, to be replaced with a FlatPlate® 3x8 model, 3.3"W x 7.8"H

B10, CB25, CB26 models are, 4.0"- 4.5"W x 12"H, to be replaced with a FlatPlate® 5x12 model, 4.9"W x 12"H

B45, B50 models are, 9.5"-10"W x 20"H, to be replaced with a FlatPlate® 10x20 model, 9.8"W x 20"H

CB75, CB76 models are 7.5"W x 24.5"H to be replaced with a FlatPlate® 10x20 model, 9.8"W x 20"H

Pressure Rating

All FlatPlate® FP series models are rated for 450 psig, equal to or greater than the units listed above.

FlatPlate® MPN marine models can be substituted at 300 psig rating.

Failure Analysis

If the unit being replaced has been in service for less than 5 years (Plate Heat Exchanger or Shell & Tube), the cause or mode of failure may repeat itself, due to water quality, and other factors.

An MPN Marine Series unit is recommended for units being replaced that have been in service less than 5 years.

A failure analysis report can be performed by FlatPlate® for non-FlatPlate® models, for a nominal cost, as part of a replacement heat exchanger order.

Plate & Frame Replacements

Many Plate and Frame heat exchangers (with gaskets) sometimes fail over time and can also be replaced with a FlatPlate® model.

Information Please contact your local FlatPlate® representative for assistance.needed for replacement includes dimensions of the plates, number of plates, and GPM flow rates.

Accessories

Mounting Brackets

Mounting of any brazed plate unit can be accomplished by 1) using a bar across the face of the unit, or, 2) mounting to a steel strut, or 3) by using a mounting bracket. GEA FlatPlate's mounting brackets are designed for easy use, where applicable. BKT and FR models are all stainless steel.

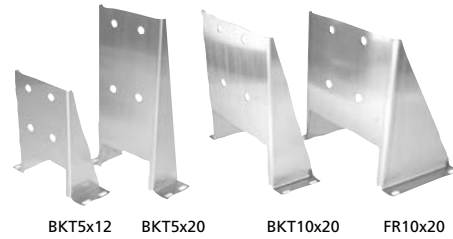

Bracket Model	Type	For Models
BKT5x12	Mounting Bracket for 5x12 models	CH-1/2A thru CH5A, C1/2A thru C5A, SC1 thru SC14, All 5x12 Fluid to Fluid
BKT5x20	Mounting Bracket for 5x20 models	CH1-1/2 thru CH15B, C1/2 thru C15B, All 5x20 Fluid to Fluid
BKT10x20	Mounting Bracket for 10x20 models, 10 to 80 plates	CH10 thru CH30, C10 thru C80, SC16 thru SC54, Fluid to Fluid up to 80 plates
FR10x20	Rugged Floor Mounting Frame for 10x20 models, 90 to 200 plates	CH35 thru CH80, SC66 thru SC120, Fluid to Fluid 90 to 200 plates

BKT5x12 & BKT5x20

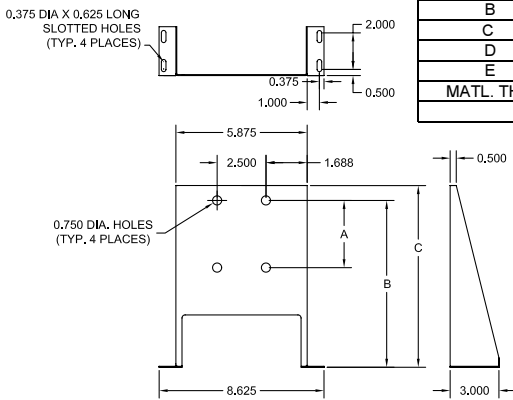

PART #	BKT10X20	FR10X20	BKT5X20	BKT5X12
A			5.500	3.500
B			13.625	8.625
C			14.875	9.750
D	3.000	7.000		
E	4.000	8.000		
MATL. TH'K	14 GA	10 GA	14 GA	14 GA

MATERIAL: SA-240, 304 SS

BKT & FR10x20

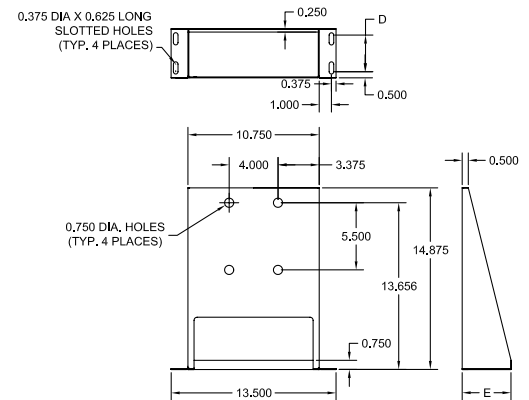

"y" Strainers



A Water strainer is required for proper protection of the brazed plate fluid side for chillers, condensers, and fluid to fluid units. These strainers are cast bronze, FPT female pipe connection and rated for 400 psi working pressure at 150°F.

Model	Female Pipe connection	Mesh Strainer	GPM @ 1 psi PD	GPM @ 2 psi PD
STR3/4	3/4" FPT	20 mesh	18	26
STR1	1" FPT	20 mesh	28	40
STR1-1/4	1-1/4" FPT	20 mesh	42	60
STR1-1/2	1-1/2" FPT	20 mesh	70	100
STR2	2" FPT	20 mesh	110	140
STR2-1/2	2-1/2" FPT	20 mesh	140	190
STR3	3" FPT	20 mesh	180	260
STR4	4" FPT	20 mesh	300	420

Zinc Anode



Model	Female Pipe Connection
ANODE 3/8	3/8" FPT

A Zinc Anode is required for all MCN & MPN models used in Swimming Pools with electronic chlorinators and for ALL applications where galvanic corrosion is possible. A Zinc Anode is installed and shipped with all MCN Condensers, and not provided with MPN fluid to fluid models.

Accessories

Insulation Kits



Insulation Kits are available and recommended for all CH, SC and all other FlatPlate® models to prevent excessive sweating, ice build-up, or heat loss. Designed to be applied quickly in 10 minutes or less, the Insulation Kits consist of three sections: a pre-cut front, back and side panel made from 1/2" black Armaflex, with extra strength adhesive backing.

Single insulation kit recommended for Evaporator temperatures 20°F or higher
 Minimum operating temperature: -40°F. Maximum operating temperature: 220°F

Insulation Kit Model	Use with GEA FlatPlate Model
3x8" Models	
IN-CH3x8-14	CH3x8-14
IN-CH3x8-20	CH3x8-20
IN-CH3x8-30	CH3x8-30
IN-CH3x8-40	CH3x8-40
5x12" Models	
IN-CH1/2A	CH1/2A
IN-CH3/4A	CH3/4A
IN-CH1A	CH1A
IN-CH1-1/2A	CH1-1/2A
IN-CH2A	CH2A
IN-CH2-1/2A	CH2-1/2A
IN-CH3A	CH3A
IN-CH3-1/2A	CH3-1/2A
IN-CH4A	CH4A
IN-CH5A	CH5A
5x20" Models	
IN-CH1-1/2	CH1-1/2
IN-CH2	CH2
IN-CH2-1/2	CH2-1/2
IN-CH3	CH3
IN-CH4	CH4
IN-CH5	CH5
IN-CH6	CH6
IN-CH7-1/2	CH7-1/2
IN-CH10B	CH10B
IN-CH12B	CH12B
IN-CH15B	CH15B

Insulation Kit Model	Use with GEA FlatPlate Model
10x20" Models	
IN-CH10	CH10
IN-CH12	CH12
IN-CH15	CH15
IN-CH20	CH20
IN-CH25	CH25
IN-CH30	CH30
IN-CH35	CH35
IN-CH40	CH40
IN-CH50	CH50
IN-CH60	CH60
IN-CH70	CH70
IN-CH80	CH80
10x20-2 Circuit Models	
IN-CH10-2C	CH10-2C
IN-CH12-2C	CH12-2C
IN-CH15-2C	CH15-2C
IN-CH20-2C	CH20-2C
IN-CH25-2C	CH25-2C
IN-CH30-2C	CH30-2C
IN-CH35-2C	CH35-2C
IN-CH40-2C	CH40-2C
IN-CH50-2C	CH50-2C
IN-CH60-2C	CH60-2C
IN-CH70-2C	CH70-2C
IN-CH80-2C	CH80-2C

CH80M thru CH160 - Consult the Factory
 Models FP, FPN & others - Consult the Factory

Insulation Kit Model	Use with GEA FlatPlate Model
Subcoolers	
IN-SC1	SC1
IN-SC2	SC2
IN-SC3	SC3
IN-SC5	SC5
IN-SC7	SC7
IN-SC10	SC10
IN-SC12	SC12
IN-SC14	SC14
IN-SC16	SC16
IN-SC22	SC22
IN-SC28	SC28
IN-SC35	SC35
IN-SC42	SC42
IN-SC54	SC54
IN-SC66	SC66
IN-SC80	SC80
IN-SC90	SC90
IN-SC100	SC100
IN-SC120	SC120

- NOTES:**
1. All insulation Kits are three piece die cut, with front, back and side wrap-a-round, 1/2" Armaflex, with peel off pre-glued backing.
 2. Rated for 20°F minimum, 220°F maximum temperatures.
 3. For <20°F, Two insulation kits recommended. Consult the Factory for correct models.

Field Application Tips

Fluid Chillers

For projects involving comfort cooling for large homes, commercial or industrial cooling, or process cooling, a Fluid Chiller can be configured using standard industry condensing units, both residential and commercial versions. These applications are typically non-critical temperature control and allow a highly economical and reliable installation.

FlatPlate® units also are used in widely available process fluid chillers packages, available from a number of manufacturers for greater capabilities, precision fluid temperature control and other features.

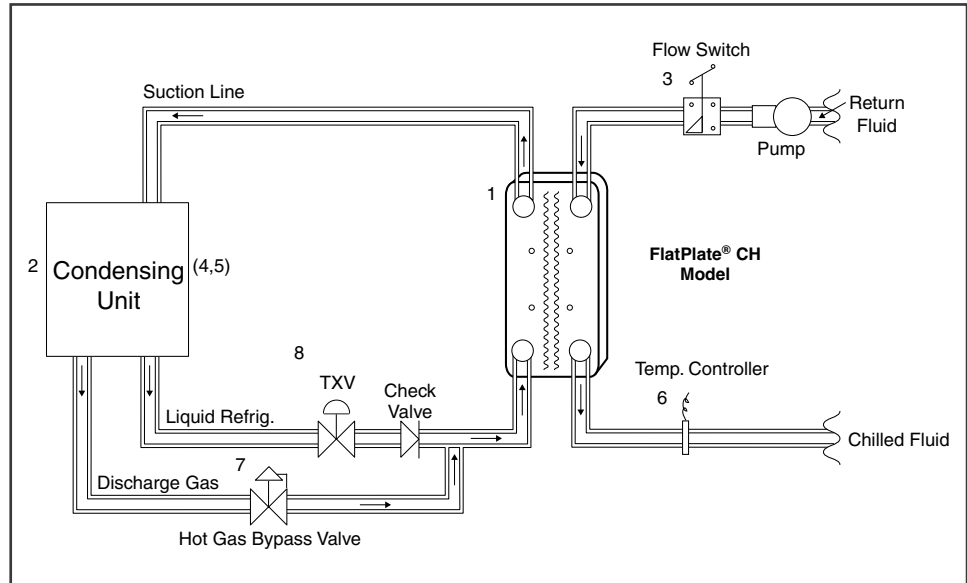
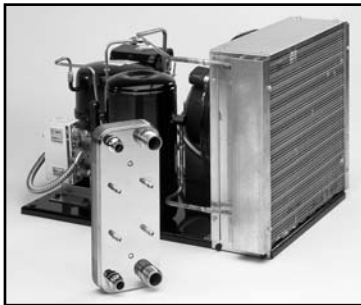

Applications Tips:

Condensing Unit Selection: A basic fluid chiller can be put together using a standard FlatPlate® CH or CHN Series Chiller (evaporator) and a standard high, medium or low temp condensing unit. Matching BTUH performance of the condensing unit (at design Etp Evap Temperature at design Evap Pressure) to the appropriate FlatPlate® Model (or one model larger) is highly important. For example: For a condensing unit rated at 230,000 BTUH at 45F Etp, use a FlatPlate® model CH20 or CH25. Note: Under-sizing the FlatPlate® unit, or over-sizing the condensing unit could cause freeze conditions. Evap temps below 34F should be avoided, unless glycol or non-freezing fluid is used. Other: a) Applications below 25F Etp should include use of oil separator. b) Applications with high transient loads should use suction accumulator. c) Suction to Liquid heat exchanger recommended for applications with long suction or liquid pipe runs.

Pumps: Fluid pump should be sized for 2.4gpm to 3 gpm per ton, with ample pump head capacity for the heat exchanger, piping, and load for full flow. Variable flow through a FlatPlate® Chiller is not recommended. For medium and low temp applications, be sure to include pump power and piping thermal losses in the load calculations.

Controls & Freeze Protection: Proper controls are required to maintain fluid temperatures and prevent freeze conditions. 1. A flow switch or differential pressure switch must be used to verify that fluid flow exists before the refrigerant circuit is activated. 2. A low pressure cut out must be incorporated into the suction line after the heat exchanger, set to cut off the compressor should the refrigerant pressure decrease below the equivalent freeze point of the fluid being chilled, but no less than 28°F for water chillers. 3. A temperature controller should be utilized to maintain fluid temperatures. Compressor anti-cycling may be needed. 4. A hot gas bypass valve and modulating control should also be utilized for low load control, and part load requirements, if needed. 5. Digital pulsing expansion valves and digital (on/off) hot gas valves are not suitable.

Application Selection: For applications using water, 9F to 10F approach temps (Leaving water temp minus Etp Evap temp), use standard models. For all other design conditions, glycols oils, and other fluids, contact your local GEA FlatPlate rep or distributor for a computer selection.

Item: (Bill of Material)

1. FlatPlate® Heat Exchanger
2. Condensing Unit
3. Flow Switch
4. L.P. Cut-Out (may be included w/cond. unit)
5. H.P. Cut-Out (may be included w/cond. unit)
6. Temperature Control
7. Hot Gas Bypass Valve
8. TXV

Manufacturer:

GEA PHE Systems North America, Inc.
 Copeland, Tecumseh, HeatCraft, Maneurop, Bitzer, others
 Johnson Controls, United Electronics, and others
 Ranco, Penn, and others
 Ranco, Penn, and others
 Honeywell Air/Water, HeatCraft others
 Sporlan, Alco
 Sporlan, Alco, Danfoss

Field Application Tips

Process Fluid Chillers with Storage Tank

Fluid Chillers with storage tanks have several advantages, including: 1) better process temperature control 2) higher transient load capabilities 3) ability to handle variable flow rates, 4) better compressor/chiller operation and 5) sometimes, allows for smaller chillers, depending upon the average and peak loads. Some process applications also have highly variable loads and require chilled fluid storage tanks, or make-up water tanks. A Fluid Chiller can be configured (same as previous section), integrating a standard storage tank, 40 to 200 gallons, or larger up to several thousand gallons.

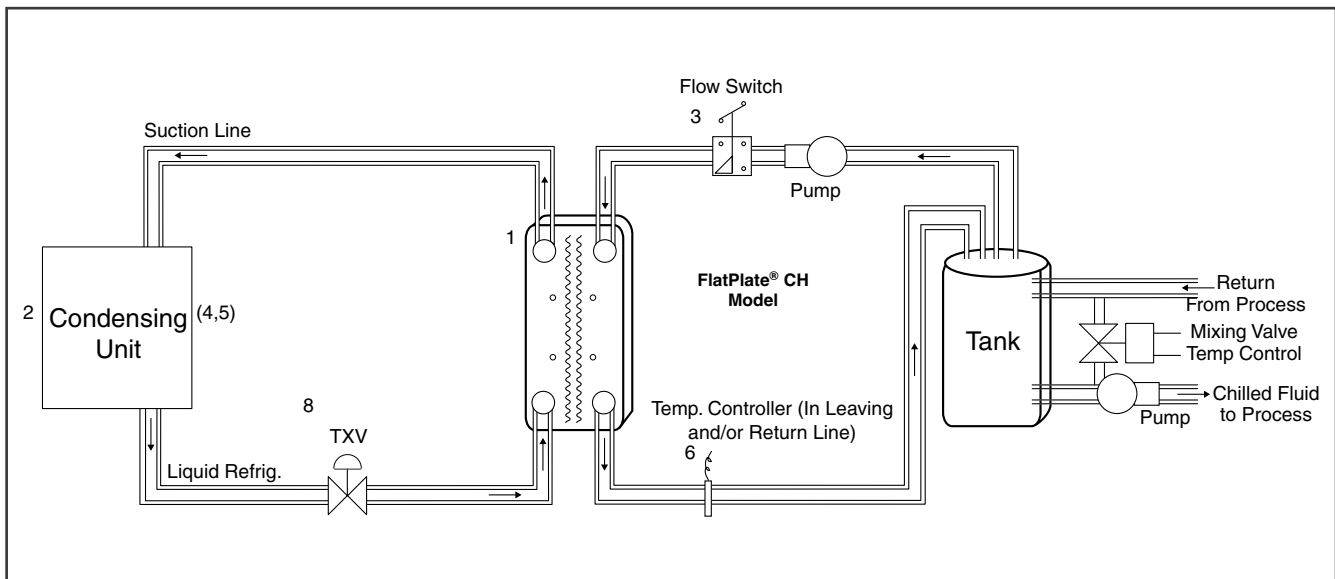

Applications Tips:

Condensing Unit Selection: When combined with a Fluid Storage tank, the overall compressor size and condensing unit selection is sometimes smaller, yet highly dependent upon pull-down rate required for the tank, tank recovery rate needed, and maximum transient load, if a continuous full load is not always present. Tank size selection is also important.

Piping: The pump for the chiller is the same 2.4gpm to 3 gpm per ton, but is constantly re-circulated to the tank. This allows variable flow or and constant flow to the load. A temperature control mixing valve can be added to provide precise fluid temp control, if needed.

Controls: Proper controls are required to maintain fluid temperatures and prevent freeze conditions.

1. A flow switch or differential pressure switch must be used to verify that fluid flow exists before the refrigerant circuit is activated.
2. A low pressure cut out must be incorporated into the suction line after the heat exchanger, set to cut off the compressor should the refrigerant pressure decrease below the equivalent freeze point of the fluid being chilled, but no less than 28F for water chillers.
3. A temperature controller should be utilized to maintain fluid temperatures. Compressor anti-cycling may be needed.
4. A hot gas bypass valve is typically not needed depending upon tank size.
5. Digital pulsing expansion valves and hot gas valves are not suitable.

Application Selection: For applications using water, 9F to 10F approach temps (Leaving water temp minus Etp Evap temp), use standard models. For all other design conditions, glycols oils, and other fluids, contact your local FlatPlate® rep or distributor for a computer selection.

Field Application Tips

Fluid Isolation - Special Cooling Processes

Some cooling applications require fluid isolation, such that 1) any possible failure of the refrigeration system will not contaminate the process with refrigerant or refrigerant oil, and/or 2) to properly control the process, or 3) protect the refrigeration system. These applications require a second FLUID TO FLUID heat exchanger and pump to be installed, in addition to the refrigeration chilled fluid loop.

Taking the simple step to put in an Isolation Heat Exchanger, is good design practice for system reliability, safety, and easier maintenance.

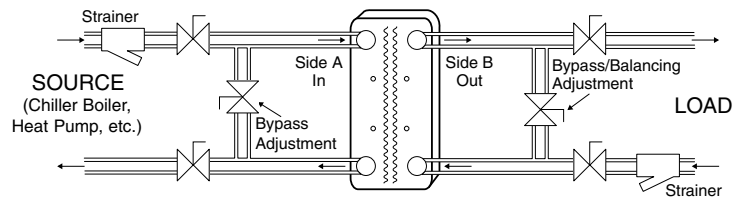

Isolation Heat Exchangers are especially required for:

- Potable make-up water
- Water chilling to 35F for bakeries
- Ethylene Glycol to Potable water
- Food process fluids
- Wine and liquor cooling
- Live fish and wildlife cooling
- Critical (and medical) fluids and gases
- High temperature fluids (ie, water or oil)
- Cooling acids or solvents
- Machinery oil cooling
- Hydraulic systems cooling
- Fluids with particulates

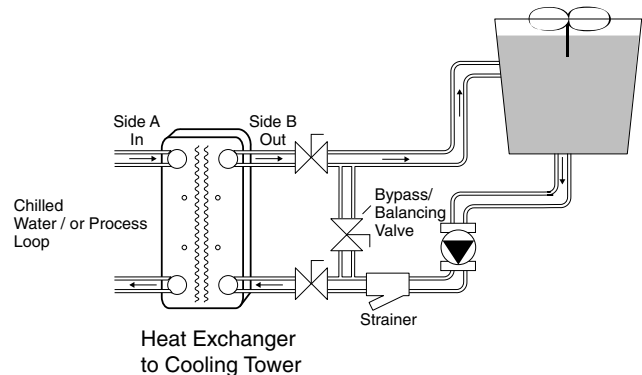

Isolation Heat Exchangers are also very popular in industrial manufacturing operations where a plant chilled water (or glycol) loop is present. Isolation (or Interface) Heat Exchangers can be used to interface machinery and process needs, to provide high quality temperature control and to protect the machinery from variable water quality.

Application Tips:

Heat Exchanger Selection(s): Typically a FlatPlate® FLUID TO FLUID model is selected based on a 10F approach (Chiller Fluid Loop Design Temp minus the Process Loop Design Temp). Approaches of 5 to 6F are also practical and approaches of 2-3F are also possible, but less economical. Depending upon the fluid or application, and FP, FPN, or MPN model is chosen based on design conditions and overall BTUH load. A computer selection is required. Contact your local FlatPlate® representative or distributor.

Piping: The chilled Fluid loop should be a constant run-a-round loop, whereas the Process loop can be variable or constant.

Controls: Several methods of control are possible, depending upon the requirement. The Process loop temperature can be controlled by modulating the Chilled Fluid bypass valve, or modulating a Process loop valve, or left to run full at all times, but controlling the Chiller/Compressor.

Special Notes:

1. 35 F Water - For applications requiring 35F potable water on the process side, the Chilled Fluid loop should be 15% or greater Propylene Glycol, operating at 28F to 30F. The appropriate Isolation Heat Exchanger can be selected for 5F approach for achieving 35F water temperatures.
2. High Temperature Fluids or Oils - For Cooling 80F to 220F temperature fluids, the appropriate heat exchanger is typically selected based on 50F Entering Chilled Water/ 60F Leaving and the Process Fluid temperatures as desired. This allows the Fluid Chiller to operate normally and the Isolation Heat Exchanger to be very small and cost effective.
3. Fish and Aquatic Wildlife - Many fish and crustaceans are toxic to copper. Use only MPN Series, Polymer, or Titanium for the Isolation heat exchanger.
4. For compatibility with special fluids, contact your local FlatPlate® representative or distributor.

Field Application Tips

Chiller Barrel Replacement

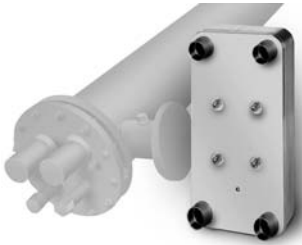

FlatPlate® CH and CH-2C models can be used for replacement of chiller barrels in comfort cooling chillers and process chillers. The GEA FlatPlate unit will be significantly smaller and easier to install, and require some piping installation modifications.

The overall reasons to use a FlatPlate® CH, CH-2C or CHN Series unit include lower installed cost, lower shipping costs, easier rigging and installation, and much less space needed.

Application Tips:

Heat Exchanger Selection: The FlatPlate® heat exchanger should be selected based on total BTUH load (design tons at 12,000 BTUH/ton), based on design Etp (Evaporator Temperature at Pressure) and Fluid Temperatures IN/Out and flow rate. For most applications used 2.4 gpm per ton and select from the standard models, based on 9F or 10F approach. Over-sizing one or two models is ok. If operating conditions are different than standard, contact your local FlatPlate® rep or distributor for a computer selection.

Fluid Piping: Strainer is recommended to catch debris in pipes. Heat exchanger must be piped in counterflow.

Controls: Use existing low pressure (LP) cut-out and flow switch for primary safety controls. Check all controls for proper operation. For water chiller, LP cut-out should NOT be set below 28F based on refrigerant pressure. Note: Leaving chilled water cut-out is not adequate to protect any evaporator heat exchanger from freeze-up. If pump-down cycle is present, set LP cut-out at 28F or 4F below freezing temperature of fluid.

Key Considerations: 1. If the FlatPlate® heat exchanger is being used to replace a failed chiller barrel, determine the cause of the failure (ie low pressure cut-out failure or flow switch failure) and thoroughly check out the system operation.

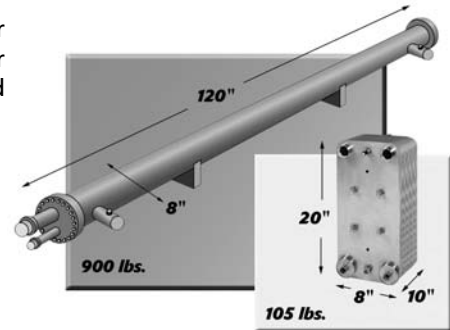

35 Ton Chiller shown

Condensers (Replacement & New Applications)

FlatPlate® C and MCN models are used widely for water-cooled systems and replacement of shell & tube condensers. The overall reasons to use a FlatPlate® C Series or MCN Series unit include lower installed cost, lower shipping costs, easier rigging and installation, and much less space needed.



Condenser replacements include:

Comfort Chillers, Modular Chillers, Process Equipment, Ice Machines, Fan Coil / Terminal / Heat Pumps, Supermarket systems, Computer room systems

Condensers for new applications also include:

Closed loop systems using Dry Coolers (Air to Water), Process Chillers, Refrigerated Warehouses, Floor warmers, Walk-in Freezers, Supermarket systems, Earth-Coupled Heat Pumps, Lake & River Water

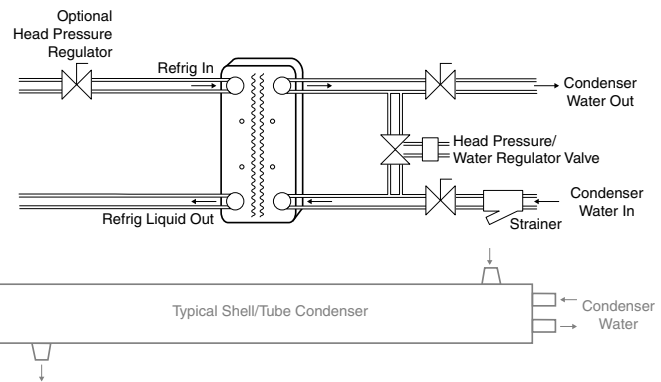

Application Tips:

Heat Exchanger Selection: The FlatPlate® heat exchanger should be selected based on total BTUH heat of rejection (tons at 15,000 BTUH/ton), based on design Ctp (Condensing Temperature) and Water Temperatures IN/Out and flow rate. For most applications used 3 gpm per ton and select from the standard models. Over-sizing one or two models is ok. If operating conditions are different than standard, contact your local FlatPlate® rep or distributor for a computer selection. For closed loop condensers, use C Series. For open loop condensers using cooling towers, applications with variable water quality, consider using the MCN Series. For lake water, water with pH below 6.0, brackish water or sea water, use the MCN Series.

Waterside Piping: A 20 to 60 mesh strainer MUST be installed on the condenser waterside to protect from pipe debris and tower debris. Heat Exchanger MUST be piped in counter-flow.

Controls: A water flow regulator valve used to control compressor head pressure is typical. However, if water flow rates drop below 1 gpm per ton (for open loop systems), or water content has high scale build up, a) use a pump "run-a-round" loop to maintain constant flow to the condenser, or b) use a discharge head pressure regulator valve to maintain compressor head pressures, while maintaining lower condensing pressures (thus higher water flow rates for lower fouling and better system control).

Key Considerations: If the FlatPlate® condenser is being used to replace a failed shell & tube condenser, or coiled coaxial condenser, consider the life of the previous condenser and reason it failed. Upgrading to the MCN model may improve overall life and customer satisfaction.

Quick Reference Calculations

BTU	=	Amount heat required to raise (heat or cool) 1 lb of water 1°F
	=	1054.8 Joules
	=	252 gram-calories
BTU/H hour	=	Amount of heat over time to raise (heat or cool) 1 lb of water 1°F in ONE
BTU/H (water at 68°F)	=	Temp Difference x GPM x 500
BTU/H (30% E. Glycol at 68°F)	=	Temp Difference x GPM x 445
BTU/H (50% E. Glycol at 20°F)	=	Temp Difference x GPM x 375
BTU/H (Most Oils)	=	Temp Difference x GPM x 250
BTU/H (any liquid or gas)	=	$\frac{\text{Temp Difference} \times \text{Specific Heat (BTU/lb}^\circ\text{F)}}{\text{Mass Flow Rate (lbs/hr)}}$
	=	$\frac{\text{Temp Difference} \times \text{Specific Heat (BTU/lb}^\circ\text{F)} \times \text{Density (lb/cu ft)}}{7.4805}$
Celsius (°C)	=	$(^\circ\text{F}-32) \times 5/9$
Conductivity (BTU/hr-ft ² -°F.ft)	=	°C/cm x .05782
1 Cubic Foot	=	7.481 Gallons
	=	1728 Cubic inches
	=	38.32 liters
Density (lb/cu ft)	=	Specific Gravity x 62.344
	=	g/ml x 62.4
Fahrenheit (°F)	=	$(^\circ\text{C} \times 9/5) + 32$
1 Ft. of Head	=	2.307 psi (lbs per sq inch)
1 Foot of Water (68°F)	=	.4335 psi (lbs per sq inch)
	=	.2930 watts
1 Horsepower (boiler)	=	34.5 lb of steam at 212°F
	=	33476 BTU/hr
1 Gallon	=	8.346 lbs of water at 68°F
	=	231 cubic inches
	=	3.785 liters
GPM	=	.060308 Liters/sec
	=	3.62 Liters/min
Kelvin (°K) to °F	=	K x 1.8 - 459.7
Kilowatt (KW)	=	3414 BTU/hr
1 Lb of Water	=	.01602 Cu Ft
	=	27.68 Cu inches
	=	.120 gallons
1psi (Pound/sq in)	=	2.307 Feet of water
	=	2.036 inches of Mercury
	=	.06802 Bar (atmospheres)
	=	°R + 459.67
Rankin (°R) to °F	=	
Specific Heat (BTU/lb-°F)	=	cal/g-°C x 1
Tank Capacity Calculation (gallons) (rectangular)	=	Length(ft) x Width(ft) x Depth(ft) x 7.481 (gal/cu ft)
Tank Capacity Calculation (gallons) (cylinder)	=	$\frac{\text{Diameter(ft)}^2 \times 3.14 \text{ Height(ft)} \times 7.481 \text{ (gal/cu ft)}}{4}$
Tank Heating Total Requirement (BTU total)	=	Tank Temperature Rise x Gallons x 8.346 (plus tank & piping external losses)
Tank Heating Rate (BTU/hr) (Boiler Capacity needed)	=	$\frac{\text{Tank Heating Requirement(BTU)}}{\text{Hrs (hrs desired to bring tank up to temperature)}}$
Tank Heat up Rate (hrs)	=	$\frac{\text{Tank Heating Requirement(BTU)}}{\text{BTU/hr Heat Source Boiler}}$
1 Ton (Refrigeration, chilling)	=	12,000 BTU/hr
1 Ton (Refrigeration, condensing side)	=	15,000 BTU/hr
Viscosity Cp (Centipoise)	=	Centistokes x Density(g/ml)
Viscosity (lb/ft-hr)	=	Cp x 2.42
1 Watt	=	3.413 BTU/hr

Customer Service

SHIPMENT from Stock

GEA provides Same Day/Next Day Shipping from Stock for most catalog items. Shipping is via UPS, RPS and other Freight carriers. Rush or emergency orders may be shipped UPS Red or Air Freight at customer's option.

All Prices are F.O.B. York, Pennsylvania, USA.

APPLICATION SUPPORT

GEA provides customer application support and technical assistance for all refrigeration and fluid applications. For quick product selection please FAX your design conditions and application to Fax 717-268-6163, or FLATPLATE®'S LOCAL SALES ENGINEER.

INTERNATIONAL SALES

GEA ships worldwide, via UPS, Air Freight and Ocean Freight. For International Sales, please FAX all correspondence for immediate assistance. All Product models listed are also available in Metric Sweat Connection and BSPT pipe thread fluid connections.



Heat exchangers are our business. GEA PHE Systems North America Inc. is the leading manufacturer of brazed plate heat exchangers in North America for the OEM, Wholesale and Contractor (Ammonia) market. GEA PHE Systems North America Inc. takes pride in the quality of our FlatPlate® brazed plate heat exchangers, our customer service and our commitment to the refrigeration, heating and industrial markets. From all the dedicated employees at GEA PHE Systems North America Inc. we appreciate your continued support of our FlatPlate® brand brazed plate heat exchangers.

Terms and Conditions of Sale

1. GENERAL TERMS.

1.1 Binding Contract. Unless otherwise noted in the Seller's proposal, this proposal shall lapse automatically upon the expiration of a thirty (30) day period after the date of its submission unless it has been previously accepted by Purchaser or revoked in writing by Seller. This proposal does not become a binding contract until Seller confirms the Purchaser's order in writing.

1.2 Plans, Drawing and Illustrations. Proposal pages, catalogue illustrations and preliminary drawings are submitted only to show the general style, arrangement and approximate dimensions of equipment. Seller reserves the right to make such changes of design, construction or arrangement as it deems necessary to achieve the specifications contained herein. Purchaser is to provide the drawings of all foundations, concrete construction and reinforcement and required housings, based upon Seller's equipment drawings.

1.3 Proprietary and Confidential Information. This proposal and all drawings, notebooks, operating data, specifications, and other information, data and material (whether orally disclosed, printed, handwritten, typed, numerically or computer generated, computer stored, or otherwise) furnished to Purchaser by either Seller or any of its subcontractors or suppliers shall remain the proprietary and confidential property of Seller or the subcontractor or supplier, respectively, and shall be used by Purchaser only with respect to the work covered by the contract and shall not be used by Purchaser in connection with any other project. --Such proprietary and confidential information and data shall not be shown or otherwise made available to any third party at any time without Seller's prior written consent. Neither Purchaser itself shall, nor shall Purchaser permit any third party to, reverse engineer, measure or otherwise technically examine or test Seller's equipment without Seller's prior written consent. Any such proprietary and confidential information which Purchaser determines must be disclosed to its employees, shall only be disclosed to its employees on a need-to-know basis for the operation, maintenance, and repair of the equipment provided under the contract. Intellectual property or patent rights which may be obtained on the basis of the information given or made available to Purchaser under the contract or with respect to Seller's equipment shall remain the exclusive property of Seller or its subcontractor and/or supplier, respectively.

2. SAFETY REQUIREMENTS OF PURCHASER.

Purchaser shall use, and shall train and require its employees to use and shall cause any end user to use, all safety devices, guards, and proper safe operating and maintenance procedures as prescribed by all applicable laws, rules, regulations, codes and standards and as set forth in operating and maintenance manuals and instruction sheets furnished by Seller. Purchaser shall not, and shall cause any end user not to, remove or modify any safety device, guard or warning sign. If the Purchaser fails to strictly observe any of the obligations set forth in the preceding two sentences with regard to any of Seller's equipment, Purchaser agrees to defend Seller against and indemnify and save Seller harmless from, any claim, liability or obligation (including the costs and attorneys' fees of any suit or claims related thereto) incurred by Seller as a result of persons being injured or property being damaged directly or indirectly in connection with the operation of such equipment as a result of such failure. Purchaser also agrees to indemnify and save Seller harmless from, any claim, liability or obligation incurred by Seller as a result of persons being injured or property being damaged due to Purchaser's use of Seller equipment for materials or products not specified in the contract or use of non-original replacement parts not specifically authorized in writing by Seller or due to changes in the Seller equipment made by Purchaser without Seller's specific written authorization.

3. CHANGE REQUESTS.

The Purchaser has the right to ask for variation in the scope of supply. To this end the Purchaser shall inform the Seller in due time in writing about any details of such demand ("Change Request"). The Seller shall, within 14 working days from the reception of the Change Request, make an offer in writing to the Purchaser regarding the performance of the demanded variations (additional purchase price, modified delivery periods etc.). If a longer period of time from 14 days is required to determine the delay or cost increase necessitated by the change, then the Seller must advise the Purchaser within such 14 days and proceed diligently thereafter to determine the additional costs and time required. In case the Purchaser accepts said offer the Seller shall be obliged to perform the agreed modifications subject to changes being made to the purchase order or contract to reflect the Seller's response to the Change Request. Notwithstanding the foregoing, the Seller shall not be required to accept any change which the Seller believes in good faith is technically impossible or unsafe, then the change will not be made.

4. COMPLIANCE WITH LAWS.

The equipment or work purchased from Seller shall comply with all applicable laws, rules, regulations, codes and standards of all federal, state, local and municipal governmental agencies having applicable regulatory jurisdiction, as such laws, rules, regulations, codes and standards are in effect on the date of the contract, provided that: (i) the Purchaser will include in its specifications or will bring to the attention of Seller in writing any state, local or municipal laws, rules, regulations, codes or standards which are different from those imposed by the federal governmental agencies and authorities; (ii) if any such federal, state, local or municipal laws, rules, regulations, codes or standards are changed, or if new laws, regulations, codes or standards or interpretations thereof are enacted or adopted subsequent to the date of the contract, which require a change in Seller's equipment or work, an equitable adjustment shall be made to the contract price, delivery schedule and payment terms; and (iii) Seller does not guarantee any compliance with, nor will Seller incur any liability for failure of the equipment or work to comply with, any federal, state or local pollution control, effluent or utility control laws, rules, regulations, codes or standards.

5. PRICE AND PAYMENT.

5.1 The purchase price shall be paid in accordance with the Seller's proposal. Any right to retain due payments or to set-off counterclaims shall be excluded unless any such claim or counterclaim of the Purchaser is undisputed or has been determined by a final judgment of the competent court or arbitration court.

5.2 Whatever the means of payment used, payment shall not be deemed to have been effected before the Supplier's account has been fully and irrevocably credited.

5.3 If the Purchaser fails to pay by the stipulated date, the Seller shall be entitled to interest from the day on which payment was due. The rate of interest shall be one and one-half percent (1-1/2%) per month until the payment is made in full. Additionally, if Seller is required to expend costs and expenses in collecting any payments, Purchaser shall reimburse the Seller for such costs of collection (including reasonable attorneys fees).

In case of late payment the Seller may suspend his performance of the contract until it receives payment. If the Purchaser has not paid the amount due within three months the Seller shall be entitled to terminate the contract by notice in writing to the Purchaser and to claim compensation for the losses and damages it has incurred.

6. TRANSPORTATION; INSURANCE; RISK OF LOSS.

6.1 Transportation; Shipping.

6.1.1 Where transportation costs are prepaid, equipment will be shipped to an unloading point designated by the Purchaser. Unloading, haulage

from the designated unloading point and further necessary handling shall be at the Purchaser's risk and expense, independent of any installation services that may be requested by the Purchaser.

6.1.2 Shipping instructions are to be supplied by the Purchaser within 30 days after release of the purchase order by Purchaser. In the event Purchaser fails to supply shipping instructions, it shall be invoiced and Seller at its option may place the equipment in Seller's or any public or private storage facilities at the Purchaser's risk and expense.

6.2 Insurance. Purchaser accepts full responsibility for the safeguarding of all equipment delivered to the Purchaser until it is paid for in full. Until the contract price is paid in full, Purchaser shall provide and maintain insurance to the total value of the equipment delivered hereunder against all risks of fire and explosion in the names of Purchaser and Seller, as their respective interests may appear, and shall also provide and maintain such insurance to the above value against flood, earthquake, windstorm, cyclone, tornado, hurricanes, riot and strike and civil commotion.

6.3 Title; Right of Possession; Security for Payment. The parties mutually agree that the equipment specified herein shall at all times remain personal property regardless of the degree of its annexation to the real property and that the equipment shall not, by reason of any annexation to real property become a part thereof or otherwise a fixture. Title and right of possession of such equipment shall remain in Seller at all times. Title shall pass to Purchaser in accordance with the delivery terms for the equipment. Without waiving any rights to elect to proceed under applicable lien laws, Seller reserves a security interest in the equipment and parts furnished by it. By accepting delivery of the equipment or parts, Purchaser grants to Seller a security interest in such equipment and parts to secure the full and prompt payment for such equipment and parts until the agreed price (including any notes therefor) for such equipment and parts has been fully paid in cash. In the event of default in payment, Seller shall have all rights of repossession and other rights available to a secured party under the laws applicable thereto. Any equipment or parts may be separated from real estate for purpose of repossession by Seller or by its agent without liability for such removal if the Purchaser is in default in payment. Seller is authorized to execute, deliver and file with the appropriate filing office or offices and assignees, financing statements and other documents which Seller may require to evidence or perfect such security interest in accordance with applicable laws.

7. SELLER'S REMEDIES.

7.1 In the event of the insolvency of the Purchaser, Seller reserves the right to cancel the sale as well as the right to stop delivery of the goods and to resell same. Such a right shall not restrict or otherwise impair Seller's remedies for damages in the event of Purchaser's breach.

7.2 Should Purchaser fail to comply with the terms and conditions set forth herein, or if any writ or execution be levied on any of Purchaser's property, or a receiver be appointed, or if a petition in bankruptcy be filed by or against Purchaser, Seller may, upon election, demand the entire purchase price stated herein or may without notice or demand by process of law or otherwise, take possession of all or any of the equipment, wherever located, and retain all monies theretofore paid as compensation for the reasonable use of such equipment. If a contract arising from this proposal is breached and is placed in the hands of an attorney for collection of any balance due or enforcement of any other of Seller's remedies, Purchaser agrees to pay all reasonable attorneys' fees and other expenses, including therein paid or incurred by Seller. Purchaser hereby waives any and all claims, damages and demands against Seller arising out of the repossession, retention and repair as aforesaid. All rights and remedies contained herein are cumulative and not alternative.

7.3 Seller reserves all other rights and remedies available to it in the event of Purchaser's breach.

8. ASSIGNMENT.

The Purchaser shall not have the right to assign the agreement without the written consent of Seller.

9. INCREASE IN COST OR PRICE.

Unless otherwise noted in Seller's proposal, all prices quoted are subject to surcharges in accordance with the provisions posted on a monthly basis on the Seller's Internet site. If shipment should be delayed by Purchaser beyond sixty (60) days or as specified in the Seller's proposal, the price may be increased to the price in effect at the time the equipment is shipped.

10. SELLER'S LIABILITY; FORCE MAJEURE.

10.1 Seller shall not be liable for loss or damage of any kind resulting from: (i) Purchaser failing to supply any necessary technical data, as required; (ii) Purchaser failing to supply the apparatus, materials and services required; (iii) any changes in designs or specifications made subsequent to acceptance of this proposal; (iv) failure of suppliers to furnish purchased material or auxiliary equipment within scheduled dates provided that the purchased material or auxiliary equipment was properly ordered and appropriately expedited; (v) by any other reason beyond its control; or (vi) any delay caused by late payments by Purchaser.

10.2 Seller shall attempt to overcome but shall not be liable for any loss or damage from delay in delivery of any equipment or completion of any work as a result of causes of any kind beyond the reasonable control of Seller, such as, but not limited to, strikes or other labor difficulties, war, riots, changes in laws and regulations and other acts of governmental authorities, inclement weather, fire, flood or unavoidable casualties, or any delays in transportation of materials, or inability to obtain timely delivery of materials from suppliers where such transportation or delivery has been properly procured and appropriately expedited. In the event of any such delay, Seller will notify the Purchaser within a reasonable time after Seller becomes aware of such cause of delay and it is agreed that the time for delivery or completion shall be extended for a period of time at least equal to the time lost by reason of the delay.

11. MATERIAL AND WORKMANSHIP WARRANTY.

Seller warrants to the Purchaser that the equipment purchased from Seller is free from defects in material and workmanship for a period of twelve (12) months from the date of Purchaser's initial operation using the equipment but not more than eighteen (18) months from the date of delivery of the equipment to the Purchaser. If the equipment is installed in accordance with Seller's specifications and instructions and is used and maintained normally and properly in accordance with Seller's instructions as to maintenance and operation, as set forth in written operation and maintenance manuals and instruction sheets furnished by Seller; (ii) the equipment has not been changed without the prior written approval of Seller; (iii) Purchaser gives prompt written notice to Seller before the end of the warranty period specifying all alleged defects in the equipment purchased; and (iv) Purchaser preserves and turns over to Seller and permits reasonable inspection by Seller of all allegedly defective equipment, parts or items and access to the equipment to observe its startup, operation and maintenance.

This warranty shall not cover (i) any equipment furnished by Purchaser or any third party (other than a subcontractor of Seller), (ii) any defects arising from corrosion, abrasion, use of unsuitable lubricants, freezing or other operation outside of prescribed temperature ranges, or negligent attendance or faulty operation, (iii) ordinary wear and tear, or (iv) any defects caused by errors on the part of the Purchaser in not providing a suitable place in which the equipment is to be located, adequate foundation works, or adequate protection against influences within or outside the place in which the equipment is to be located which may affect the equipment or its operation. Notwithstanding the warranty set forth above, Seller shall not warrant any equipment, where the vendor of such equipment (other than Seller) is specified by Purchaser, for a period longer than warranted by the vendor.

UNLESS OTHERWISE EXPRESSLY STATED IN ANY DOCUMENT ATTACHED TO THESE TERMS AND CONDITIONS, THIS WARRANTY OF MATERIAL AND WORKMANSHIP IS THE ONLY WARRANTY MADE BY SELLER AND IS IN LIEU OF ALL OTHER WARRANTIES, EXPRESS OR IMPLIED, AND SELLER DISCLAIMS ON BEHALF OF ITSELF, ITS SUBCONTRACTORS AND SUPPLIERS ANY AND ALL IMPLIED WARRANTIES, INCLUDING, WITHOUT LIMITATION, WARRANTIES OF MERCHANTABILITY, FITNESS FOR A SPECIFIC PURPOSE (OTHER THAN THE PURPOSE STATED IN THE PURCHASER'S SPECIFICATIONS SET FORTH IN THE CONTRACT), SUITABILITY OR PERFORMANCE. No other promise or affirmation of fact (including but not limited to statements regarding capacity or performance of the equipment) shall constitute a warranty of Seller or give rise to any liability or obligation on the part of Seller.

Seller's obligation under this warranty and any other warranty or guarantee which is part of the contract is strictly and exclusively limited to furnishing repairs or replacements for equipment or parts determined to be defective on inspection by an authorized representative of Seller. Notwithstanding this exclusive remedy, if it is ultimately determined that the remedy fails in its essential purpose, then any action which may be brought against Seller subject to the terms of the contract will be limited to 100% of the contract price for the purchased equipment for which the exclusive remedy has so failed. Seller assumes no responsibility and shall have no liability for any repairs or replacements by Purchaser without Seller's prior written authorization. If Seller did not authorize the installation of equipment, Seller shall have no liability for the costs of removing or segregating any defective equipment so that the repairs or replacements can be made.

12. DAMAGES.

NOTWITHSTANDING ANY OTHER PROVISION OF THE CONTRACT TO THE CONTRARY:

(A) SELLER'S AND ITS SUBCONTRACTORS' AND SUBSUPPLIERS' AND OTHER RESPONSIBILITY LIABILITY WHETHER ARISING OUT OF CONTRACT OR TORT OR ANY OTHER LEGAL CONTEXT OR THEORY, INCLUDING NEGLIGENCE AND STRICT LIABILITY, UNDER THE CONTRACT, INCLUDING, BUT NOT LIMITED TO, ALL CLAIMS FOR BREACH OF ANY WARRANTY OR GUARANTEE, FAILURE OF PERFORMANCE OR DELAY IN PERFORMANCE BY SELLER OR PERFORMANCE OR NON-PERFORMANCE OF THE PURCHASED EQUIPMENT SHALL NOT EXCEED THE CONTRACT PRICE FOR THE PURCHASED EQUIPMENT; PROVIDED, HOWEVER, THAT THIS LIMITATION WILL NOT APPLY TO ANY LIABILITY OF SELLER FOR DIRECT DAMAGES CLAIMED BY PURCHASER FOR PHYSICAL DAMAGE TO PURCHASER'S PROPERTY (OTHER THAN EQUIPMENT PROVIDED BY SELLER) OR FOR DIRECT DAMAGES CLAIMED BY THIRD PARTIES FOR SUCH THIRD PARTIES' PERSONAL INJURY OR PHYSICAL PROPERTY DAMAGE (FOR WHICH PURCHASER IS LIABLE) TO THE EXTENT CAUSED BY THE NEGLIGENT ACTS OR OMISSIONS OR WILLFUL MISCONDUCT OF THE SELLER, FOR ALL OF WHICH MATTERS SELLER SHALL BE LIABLE UP TO AN AMOUNT OF \$1,000,000 IN THE AGGREGATE, AND

(B) IN NO EVENT SHALL SELLER, ITS SUBCONTRACTORS OR SUBSUPPLIERS BE LIABLE IN CONTRACT OR IN TORT OR UNDER ANY OTHER LEGAL CONTEXT OR THEORY, INCLUDING NEGLIGENCE AND STRICT LIABILITY, FOR ANY SPECIAL, PUNITIVE, INDIRECT, INCIDENTAL OR CONSEQUENTIAL DAMAGES OF ANY KIND OR CHARACTER, INCLUDING, BUT NOT LIMITED TO, LOSS OF USE OF PRODUCTIVE FACILITIES OR EQUIPMENT, COSTS OF PRODUCT RECALL, PLANT DOWNTIME, DAMAGE TO OR LOSS OF PRODUCT, CHEMICALS, CATALYSTS, FEEDSTOCK OR OTHER RAW MATERIALS, LOSS OF REVENUES OR PROFITS OR LOSS UNDER PURCHASES OR CONTRACTS MADE IN RELIANCE ON THE PERFORMANCE OR NON-PERFORMANCE OF THE PURCHASED EQUIPMENT, WHETHER SUFFERED BY PURCHASER OR ANY THIRD PARTY, OR FOR ANY LOSS OR DAMAGE ARISING OUT OF THE SOLE OR CONTRIBUTORY NEGLIGENCE OF THE PURCHASER, ITS EMPLOYEES OR AGENTS OR ANY THIRD PARTY.

TO THE EXTENT THAT SELLER OR THE PURCHASER MAKES ANY CLAIM UNDER ANY FRAUD OR TORT THEORY, THIS SECTION DOES NOT CIRCUMVENTING THE LIMITATIONS AND DISCLAIMERS SET FORTH ABOVE AND IS UNSUCCESSFUL IN PREVAILING ON THOSE CLAIMS, IT HEREBY AGREES TO REIMBURSE AND INDEMNIFY THE OTHER PARTY FOR ALL ATTORNEYS' FEES AND EXPENSES AND COSTS INCURRED BY THE OTHER PARTY IN DEFENDING SUCH CLAIM.

13. ALTERATION - MODIFICATION.

No waiver, alteration or modification of the foregoing terms and conditions, except as noted in the text of this proposal shall be valid unless made in writing and signed by an authorized representative of Seller.

14. PATENTS.

Seller shall hold Purchaser harmless against any claim that Seller's equipment infringes United States apparatus patents, but Seller makes no representation or warranty, and Seller shall have no responsibility for any infringement or unfair competition resulting from the use of Seller's equipment with the Purchaser's process, or in combination with other equipment not supplied by Seller.

15. PRODUCT SELECTION AND USE.

The Purchaser shall be responsible for accurate design and operating conditions used in the selection and use of the Seller's products. The Purchaser's selection and use of Seller's products from published literature shall be at the Purchaser's risk as to appropriate application, design conditions and performance criteria use.

16. STANDARDS AND TOLERANCES.

All product dimensions and published information is subject to change without notice. All of Seller's products furnished to the Purchaser shall also be subject to tolerances and variations consistent with usages of the trade concerning dimensions, composition and mechanical properties and normal variations in performance characteristics and quality.

17. INTEGRATION CLAUSE.

By acceptance of this proposal, the Purchaser acknowledges (1) that it has not relied on any previous written, oral or implied representation, inducement or understanding of any kind or nature, (2) that Seller's proposal, including these General Terms and Conditions of Sale and any drawings incorporated in the proposal by reference, embodies the entire agreement between the Purchaser and Seller and supersedes all prior agreements and understandings, both written and oral, among the parties with respect to the subject matter hereof, (3) that the contract entered into by acceptance of Seller's proposal by the Purchaser may not be modified or terminated except in writing signed by a duly authorized representative of Seller making specific reference to the contract, and (4) the Purchaser may not assign the contract without the prior written consent of Seller.

18. DISPUTE RESOLUTION; GOVERNING LAW

Any determination, agreement or performance which is disputed or cannot be made, resolved or agreed within fourteen (14) days of the date requested by either Purchaser or Seller or such longer period for resolution as may be mutually agreed shall be submitted for resolution by the chief executive officers of the Purchaser and the Seller. It shall be a condition precedent to any subsequent proceeding that the dispute shall be submitted for resolution by such chief executive officers, but if those officers shall not reach a resolution within twenty-one (21) days of submittal of the matter, the matter shall be finally settled by arbitration under the Rules of the American Arbitration Association by one or more arbitrators appointed in accordance with such Rules. The place of arbitration will be Philadelphia, Pennsylvania. The contract between the Seller and the Purchaser and their respective performances shall be construed under and governed by the laws of Pennsylvania.

GEA PHE Systems
Competence in Heat Transfer

With emphasis on the highest quality standards and constant innovations, GEA PHE Systems continues to expand its market position: Within the GEA Process Equipment Division, GEA Ecoflex together with GEA Ecobraze, GEA WTT, GEA PHE Systems NA, GEA VIEX and GEA EcoServe forms GEA PHE Systems, the Center of Competence and Service Center for gasketed, brazed and fully welded plate heat exchangers of GEA Group:

- HVAC
- refrigeration
- sugar
- chemical
- paper
- food
- life science
- marine
- power
- renewable energy



Contact details at:
www.geaphena.com

The specifications contained in this printing unit are intended only to serve the non-binding description of our products and services and are not subject to guarantee. Binding specifications, especially pertaining to performance data and suitability for specific operating purposes, are dependent upon the individual circumstances at the operation location and can, therefore, only be made in terms of precise requests.

Your contact:



Process Equipment Division
GEA PHE Systems NA, Inc.
 100 GEA Drive
 York, PA 17406
 Toll Free: 1-800-774-0474
 Phone: 1-717-268-6200
 Fax: 1-717-268-6163
www.geaphena.com
 E-mail: info@geaphena.com